



NOVASEN

Installation, Operating & Maintenance Instructions

Butterfly Pressure Control Valve with RS232 interface

DN 40-250 mm



NOVASEN

Imprint

Manufacturer NOVASEN , Republic of KOREA

Website : www.novasen.com
Phone : +82 51 582 7071
Fax : +82 51 582 7072
Email : valve@novasen.net

Publisher NOVASEN , Republic of KOREA

Editor NOVASEN , Republic of KOREA

Print NOVASEN , Republic of KOREA

Copyright © NOVASEN

No part of these instructions may be reproduced in any way (photocopies, microfilms or any other reproduction processes) nor may it be manipulated with electronic systems, duplicated or distributed without written permission from NOVASEN. Offenders are liable to pay damages.

The original NOVASEN firmware and updated state of the art versions of the NOVASEN firmware are intended for use with NOVASEN products. The NOVASEN firmware contains a limited, time unlimited user license. The NOVASEN firmware may not be used for purposes other than those intended nor is it permitted to make copies of the NOVASEN firmware.

In particular, it is strictly forbidden to give copies of the NOVASEN firmware to other people.

The use of trade names, brand names, trademarks, etc. in these Instructions does not entitle third parties to consider these names to be unprotected and to use them freely. This is in accordance with the meaning of the laws and acts covering brand names and trademarks.

Contents:

1	Use of product.....	5
1.1	Technical data.....	5
1.1.1	Valve unit.....	7
2	Installation.....	9
2.1	Unpacking.....	9
2.2	Installation into the system.....	9
2.3	Tightening torque.....	11
2.3.1	Mounting of CF-F flanges.....	11
2.3.2	Mounting with centering rings.....	11
2.3.3	Mounting with O-ring in grooves.....	12
2.4	Admissible forces.....	12
2.4.1	Admissible forces for valve body.....	12
2.4.2	Admissible forces at controller.....	13
2.5	Requirements to sensor connection.....	14
2.6	Electrical connection.....	14
2.6.1	Sensor supply concepts.....	14
2.6.2	Power and sensor connection (+24 VDC sensors).....	15
2.6.3	Power and sensor connection (± 15 VDC sensors) <u>without</u> optional SPS module.....	17
2.6.4	Power and sensor connection (± 15 VDC sensors) <u>with</u> optional SPS module.....	19
2.6.5	RS232 interface connection.....	20
2.6.6	Service port connection.....	20
3	Operation.....	21
3.1	Introduction.....	21
3.1.1	Local operation.....	21
3.1.2	Remote operation.....	22
3.1.3	Safety mode.....	22
3.1.4	Service indication.....	22
3.2	Operation under increased temperature.....	22
3.3	Behaviour during power up.....	22
3.4	Behavior in case of power failure.....	23
3.5	Display information.....	24
3.6	Setup procedure.....	26
3.6.1	Interface configuration.....	26
3.6.2	Valve and sensor configuration.....	26
3.6.3	ZERO.....	27
3.6.4	LEARN.....	28
3.7	Close valve.....	30
3.8	Open valve.....	30
3.9	Position control.....	30
3.10	Pressure control.....	30
3.10.1	Operation with 2 sensors.....	31
3.10.2	Tuning of control performance.....	32
3.11	RS232 interface.....	35
3.11.1	Settings.....	35
3.11.2	Schematics.....	36
3.11.3	Digital inputs.....	38
3.11.4	RS232 Command syntax.....	39
3.11.5	Control commands.....	39
3.11.6	Inquiry commands.....	40
3.11.7	Setup commands.....	45
3.11.8	Error messages.....	50
4	Trouble shooting.....	51
5	Maintenance & repairs.....	54
5.1	Maintenance procedures.....	55
5.2	Option board.....	60
5.2.1	Durability of power fail battery.....	60
5.2.2	Retrofit / replacement procedure.....	61
6	Drawing.....	64

1 Use of product

This product is a Butterfly control valve for downstream pressure control in vacuum systems.

Use product for clean and dry indoor vacuum applications under the conditions indicated in chapter «Technical data» only!
Other applications are only allowed with the written permission of VAT.

1.1 Technical data

Control and actuating unit	
Power input ¹⁾	+24 VDC ($\pm 10\%$) @ 0.5 V pk-pk max. [connector: POWER]
Sensor power supply ²⁾	
Input	+24 VDC / 1500 mA max. [connector: POWER]
Output	± 15 VDC ($\pm 5\%$) / 1000 mA max. [connector: SENSOR]



Control and actuating unit (continuation)		
Sensor input Signal input ADC resolution Sampling time	0-10 VDC / Ri>100 kΩ 0.23 mV 10 ms [connector: SENSOR]	
Digital inputs ³⁾	±24 VDC max.	
Digital outputs ³⁾ Input voltage Input current Breaking capacity	70 VDC or 70 V peak max. 0.5 ADC or 0.5 A peak max. 10 W max.	
PFO ⁴⁾ battery pack Charging time Durability	2 minutes max. up to 10 years @ 25°C ambient; refer to «Durability of power fail battery» for details	
Ambient temperature	0 °C to +50 °C max. (<35 °C recommended)	
Pressure control accuracy	0.1% of sensor full scale	
Position resolution / position control capability	20000	
Actuating time	closing	0.3 s typ.
	opening	0.3 s typ.
Utilizable valve torque	2.5 Nm	

- 1) Internal overcurrent protection by a PTC device.
 - 2) Refer to chapter «Sensor supply concepts» for details.
 - 3) Refer to chapter «Schematics» for details.
 - 4) PFO = Power Failure Option. Refer to «Behavior in case of power failure» for details.
-

1.1.1 Valve unit

Valve unit	
Pressure range at 20°C	1 x 10E-8 mbar to 1.2 bar (abs)
Leak rate to outside at 20°C	1 x 10E-9 mbar l/s
Cycles until first service	2'000'000 (unheated and under clean conditions)
Admissible operating temperature	10°C to +150°C
Mounting position	Any Control unit for ISO-KF version needs support when mounted on horizontal piping and control unit does not hang.
Wetted materials - Body, plate - Shaft - Plate screws - Shaft seal - Slide bearing for shaft	Stainless steel 304 Stainless steel 304 Stainless steel 304 Stainless steel 304 Viton® (standard). Other materials available. Seal materials are declared on dimensional drawing of specific valve ordering number. iglidur® X

Valve unit (continuation)					
	DN 25 1"	DN 40 1½ "	DN 50 2"	DN 63 2½ "	DN 80 3"
Max. differential pressure on plate	1000 mbar	1000 mbar	1000 mbar	1000 mbar	1000 mbar
Min. controllable conductance (C _{min}) [N ₂ molecular flow]	0.15 l/s	0.25 l/s	0.3 l/s	0.45 l/s	0.65 l/s
Conductance in open position [N ₂ molecular flow]	22 l/s	80 l/s	150 l/s	360 l/s	850 l/s
	DN 100 4" (61240 -)	DN 160 6" (61244 -)	DN 200 8" (61246 -)	DN 250 10" (61248 -)	
Max. differential pressure on plate	800 mbar	300 mbar	150 mbar	100mbar	
Min. controllable conductance (C _{min}) (N ₂ molecular flow)	0.85 l/s	1.7 l/s	2.8 l/s	5 l/s	
Conductance in open position [N ₂ molecular flow]	1400 l/s	3800 l/s	7800 l/s	15000 l/s	
Dimensions	Refer to dimensional drawing of specific valve ordering number (available on request)				

2 Installation

2.1 Unpacking



Valves DN63 / 2½" and larger must not be lifted solely by the actuator.

2.2 Installation into the system



Fingers and objects must be kept out of the valve opening and away from moving parts. The valve plate starts to move just after power is supplied.



Do not connect or disconnect sensor cable when device is under power.

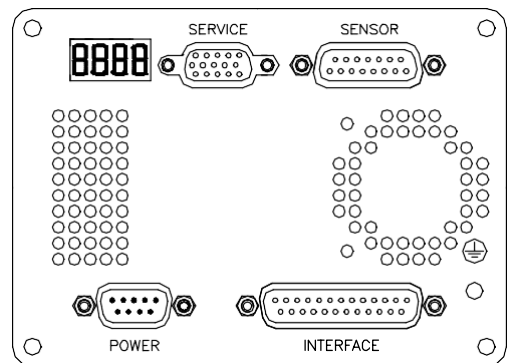
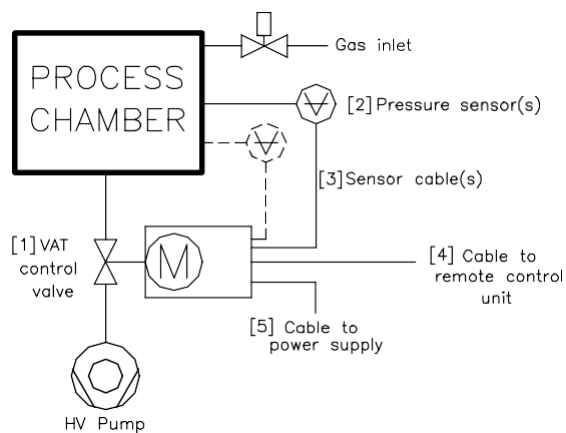

-
1. Install valve [1] into the vacuum system.

Caution: Do not tighten the flange screws stronger than indicated under «Tightening torque».

Caution: Do not admit higher forces to the valve than indicated under «Admissible forces».

Note: Make sure that enough space is kept free to do preventive maintenance work. The required space is indicated on the dimensional drawing.

Note: Control unit of valves with ISO-KF flanges needs support when mounted on horizontal piping and control unit does not hang.

2. Install the ground connection cable at controller. Refer to «Electrical connection»
 3. Install sensor(s) [2] according to the recommendations of the sensor manufacturer and directives given under «Requirements to sensor connection».
 4. Connect pressure sensor cable [3] to sensor(s) and then to valve (connector: SENSOR). Refer to chapter «Electrical connection» for correct wiring.
 5. Connect valve to remote control unit [4] (connector: INTERFACE). Refer to «RS232 connection» for correct wiring.
 6. Connect power supply [5] to valve (connector: POWER). Refer to chapter «Electrical connection» for correct wiring.
Note: To provide power to the valve motor pins 4 and 8 must be bridged, otherwise motor interlock is active and the valve enters the safety mode and is not operative. Refer also to «Safety mode».
 7. This valve may optionally be equipped with a heating device.
 8. Perform «Setup procedure» to prepare valve for operation.
Note: Without performing the setup procedure the valve will not be able to do pressure control.
-

2.3 Tightening torque

Tighten mounting screws of the flanges uniformly in crosswise order. Observe the maximum torque levels in the following table. Higher tightening torques deforms the valve body and may lead to malfunction of the valve.

2.3.1 Mounting of CF-F flanges

Tightening torques for CF-F flange connections depend on the type of seal which is used. Follow recommendations of seal manufacturer.

2.3.2 Mounting with centering rings

Valve size		max. tightening torque (Nm)		max. tightening torque (lbs . ft)	
mm	Inch	ISO-KF	ISO-F	ISO-KF	ISO-F
25	1	N/A		N/A	
40	1½	N/A		N/A	
50	2	N/A		N/A	
63	2½		8-10		6-8
80	3		8-10		6-8
100	4		8-10		6-8
160	6		13-15		9-11
200	8		13-15		9-11
250	10		13-15		9-11

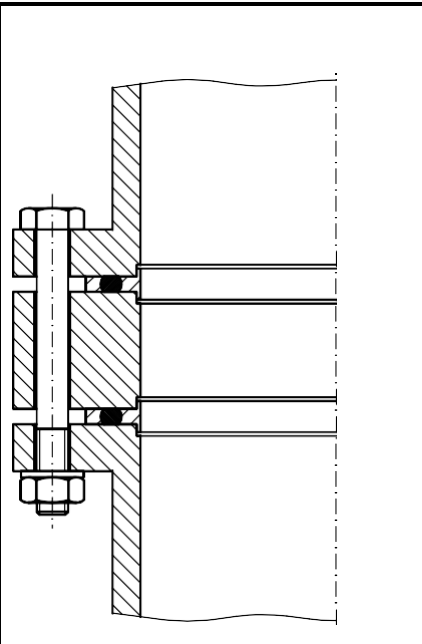

Refer to «Spare parts and accessories» for centering rings ordering numbers.

2.3.3 Mounting with O-ring in grooves

Valve size		max. tightening torque (Nm)				max. tightening torque (lbs . ft)			
mm	Inch	ISO-KF	ISO-F	JIS	ASA	ISO-KF	ISO-F	JIS	ASA
25	1	N/A				N/A			
40	1½	N/A				N/A			
50	2	N/A				N/A			
63	2½		20-23	35-40	35-40		15-17	26-30	26-30
80	3		20-23	35-40	35-40		15-17	26-30	26-30
100	4		20-23	35-40	35-40		15-17	26-30	26-30
160	6		40-45	35-40	35-40		30-35	26-30	26-30
200	8		40-45	65-70	80-90		30-35	48-52	59-67
250	10		40-45	65-70	80-90		30-35	48-52	59-67

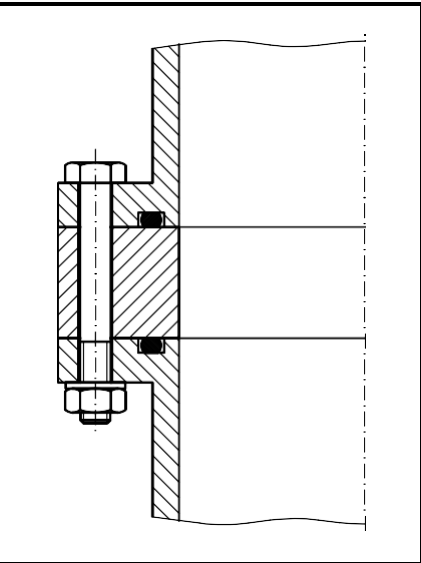

Note: Make sure that screws in use are capable to withstand applied torques.

2.4 Admissible forces

2.4.1 Admissible forces for valve body

Forces from the weight of other components can lead to deformation of the valve body and to malfunction of the valve. The stress has to be relieved by suitable means. The following forces are admissible:

Valve size		Axial tensile or compressive force «F _A »		Bending moment «M»	
mm	Inch	N	lb.	Nm	lbf.
25	1	70	16	3	3.2
40	1½	100	22	6	4.5
50	2	150	34	11	8
63	2½	800	176	32	24
80	3	850	187	35	26.5
100	4	1000	220	40	30
160	6	1200	264	60	45
200	8	1200	264	60	45
250	10	1200	264	60	45

2.4.2 Admissible forces at controller



Do not pushing, shocking load, or stressing the valve controller!

Do not deposit anything at valve controller!

The admissible force at valve controller in regards to the pedestal is shown in table below. **In case higher force is applied, the pedestal could be permanently damaged!**

Admissible force «F»	<p>Overview</p> <p>F = Force</p> <p>a = middle of aluminium part of controller (b / 2)</p>
<p>400 N</p>	

2.5 Requirements to sensor connection

To achieve fast and accurate pressure control a fast sensor response is required.

Sensor response time: < 50ms

The sensor is normally connected to the chamber by a pipe. To maintain that the response time is not degraded by this connection it needs to meet the following requirements:

Inner diameter of connection pipe: $\geq 10 \text{ mm}$
Length of connection pipe: $\leq 300 \text{ mm}$

These conductance guidelines must include all valves and limiting orifices that may also be present.

Make also sure that there is no obstruction in front of sensor connection port inside the chamber.

The sensor should also be mounted free of mechanical shock and vibration.

Dynamic stray magnetic fields may introduce noise to sensor output and should be avoided or shielded.

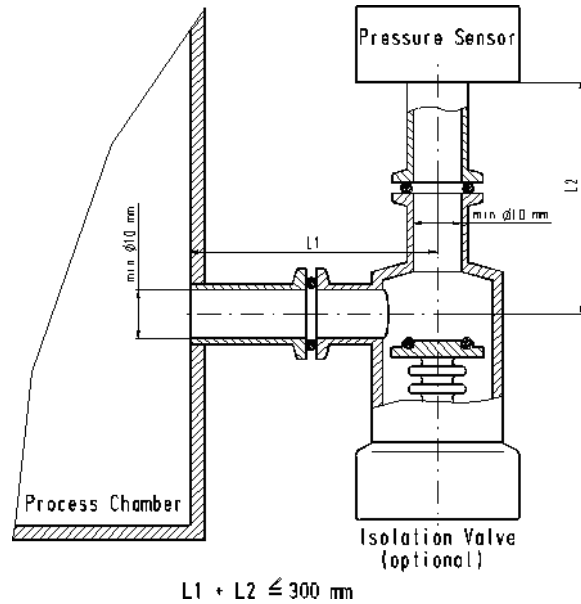

2.6 Electrical connection

2.6.1 Sensor supply concepts

This valve offers 3 alternative concepts to supply the sensor(s) with power. This depends on the sensor type and valve version that is used. This valve is available with an optional sensor power supply module (SPS) that converts $\pm 15 \text{ VDC}$ from the 24 VDC.

Concepts:

- External + 24 VDC supplied to POWER connector is feed through to SENSOR connector to supply 24 VDC sensors. Refer to chapter «2.6.2 Power and sensor connection (+24 VDC sensors)» for schematic and correct wiring.
- External $\pm 15 \text{ VDC}$ supplied to POWER connector is feed through to SENSOR connector to supply $\pm 15 \text{ VDC}$ sensors. Refer to chapter «2.6.3 Power and sensor connection ($\pm 15 \text{ VDC}$ sensors) without optional SPS module» for schematic and correct wiring.
- External + 24 VDC supplied to POWER connector is converted into $\pm 15 \text{ VDC}$ by the valve internal SPS and supplied to SENSOR connector to supply $\pm 15 \text{ VDC}$ sensors. Refer to chapter «2.6.4 Power and sensor connection ($\pm 15 \text{ VDC}$ sensors) with optional SPS module» for schematic and correct wiring.

Note: The SPS module can be retrofitted. Refer to chapter «Retrofit / replacement procedure» for instruction.

2.6.2.2 Sensor power wiring external

Pins 4 and 8 must be bridged for operation!
An optional switch would allow for motor interlock to prevent valve from moving.

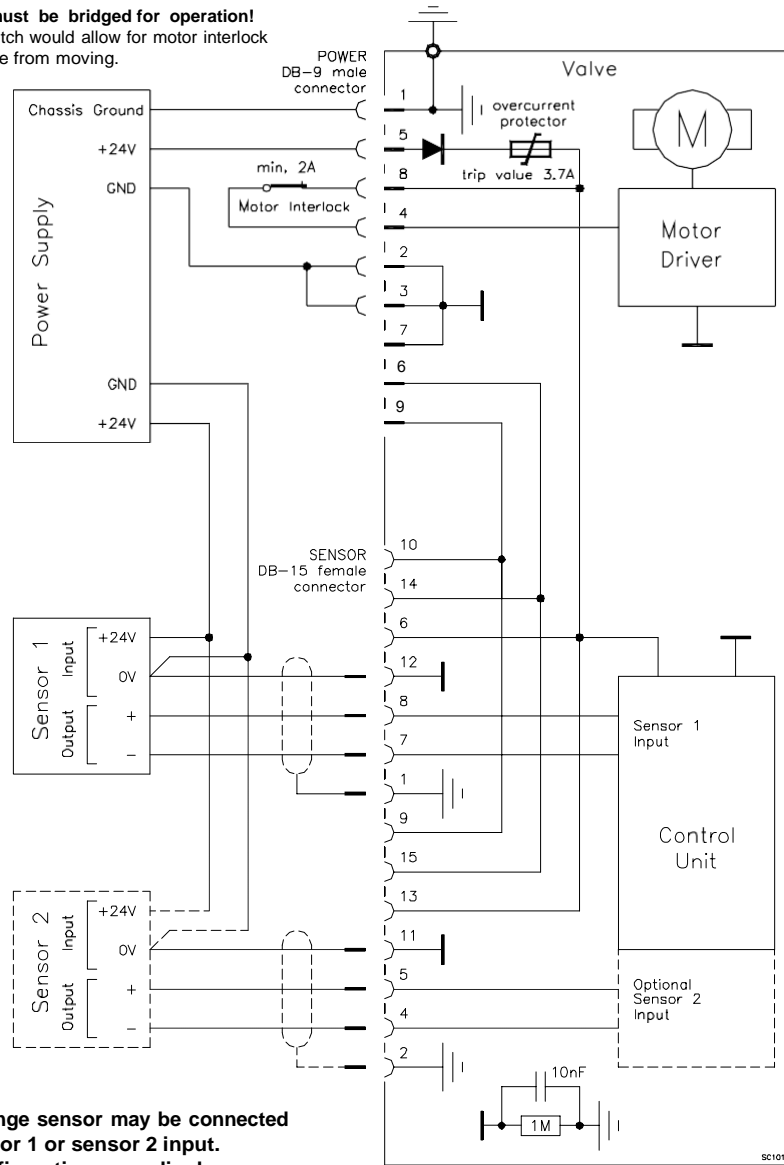

Note:

- Use shielded sensor cable(s). Keep cable as short as possible, but locate it away from noise sources.
- Connect the +24 VDC sensors at DB-15 female sensor connector exactly as shown in the drawing above. Do not connect other pins, that may damage power supply or controller!
- Connector: Use only screws with 4-40UNC thread for fastening the connectors!

2.6.3 Power and sensor connection (± 15 VDC sensors) without optional SPS module

2.6.3.1 Sensor power wiring via controller

Pins 4 and 8 must be bridged for operation!

An optional switch would allow for motor interlock to prevent valve from moving.

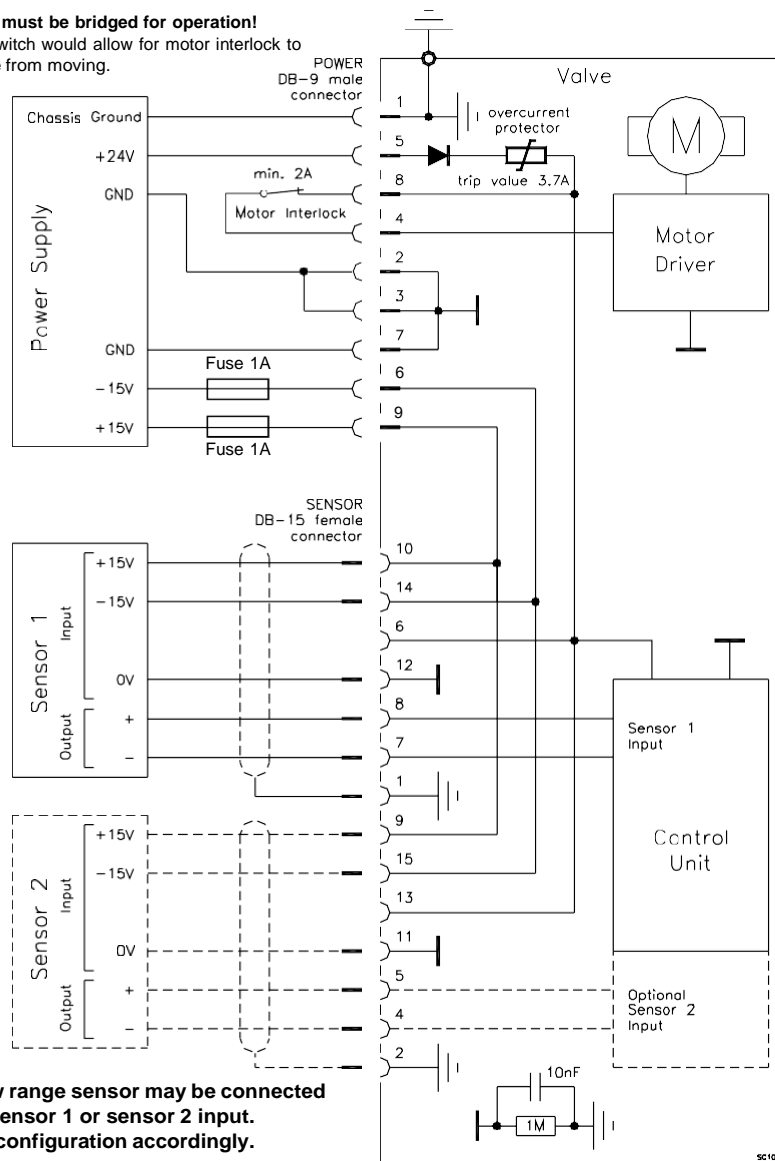

Note:

- Use shielded sensor cable(s). Keep cable as short as possible, but locate it away from noise sources.
- Connect the ± 15 VDC sensors at DB-15 female sensor connector exactly as shown in the drawing above. Do not connect other pins, that may damage power supply or controller!
- Connector: Use only screws with 4-40UNC thread for fastening the connectors!

2.6.3.2 Sensor power wiring external

Pins 4 and 8 must be bridged for operation!

An optional switch would allow for motor interlock to prevent valve from moving.

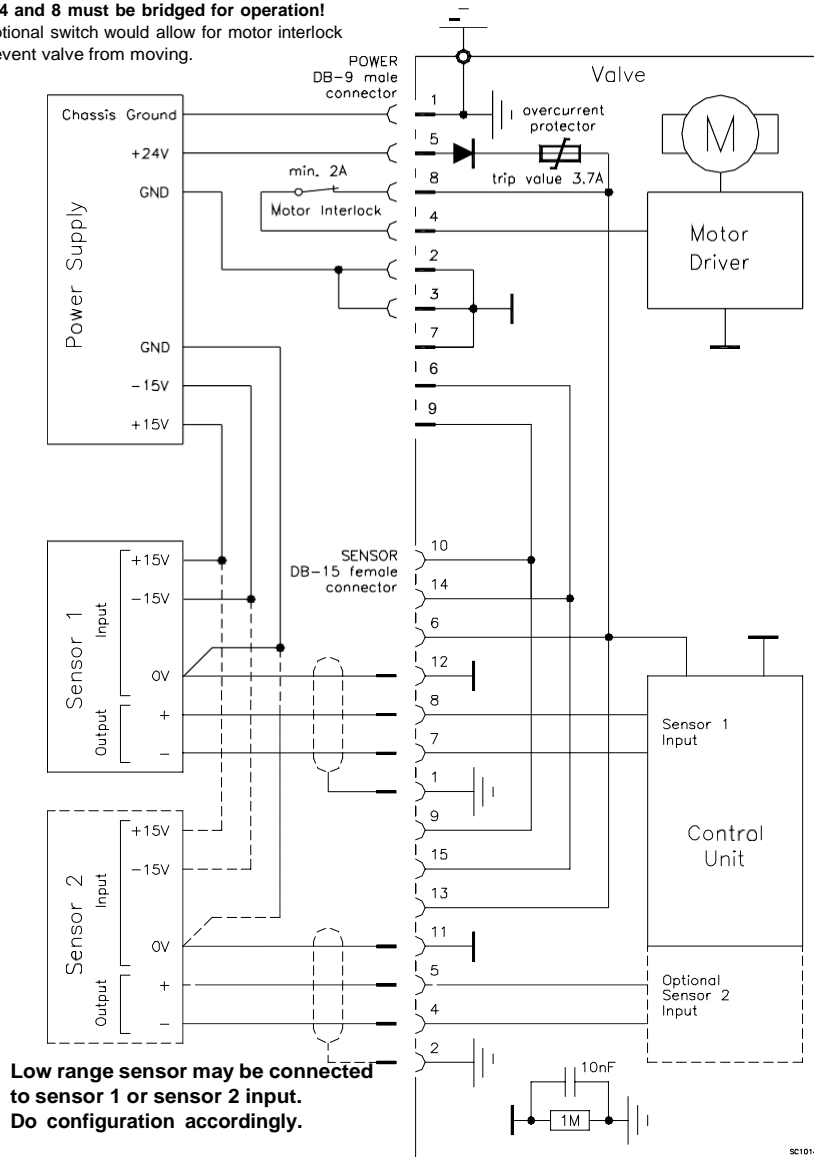

Note:

- Use shielded sensor cable(s). Keep cable as short as possible, but locate it away from noise sources.
- Connect the ±15 VDC sensors at DB-15 female sensor connector exactly as shown in the drawing above. Do not connect other pins, that may damage power supply or controller!
- Connector: Use only screws with 4-40UNC thread for fastening the connectors!

2.6.4 Power and sensor connection (± 15 VDC sensors) with optional SPS module

Pins 4 and 8 must be bridged for operation!

An optional switch would allow for motor interlock to prevent valve from moving.

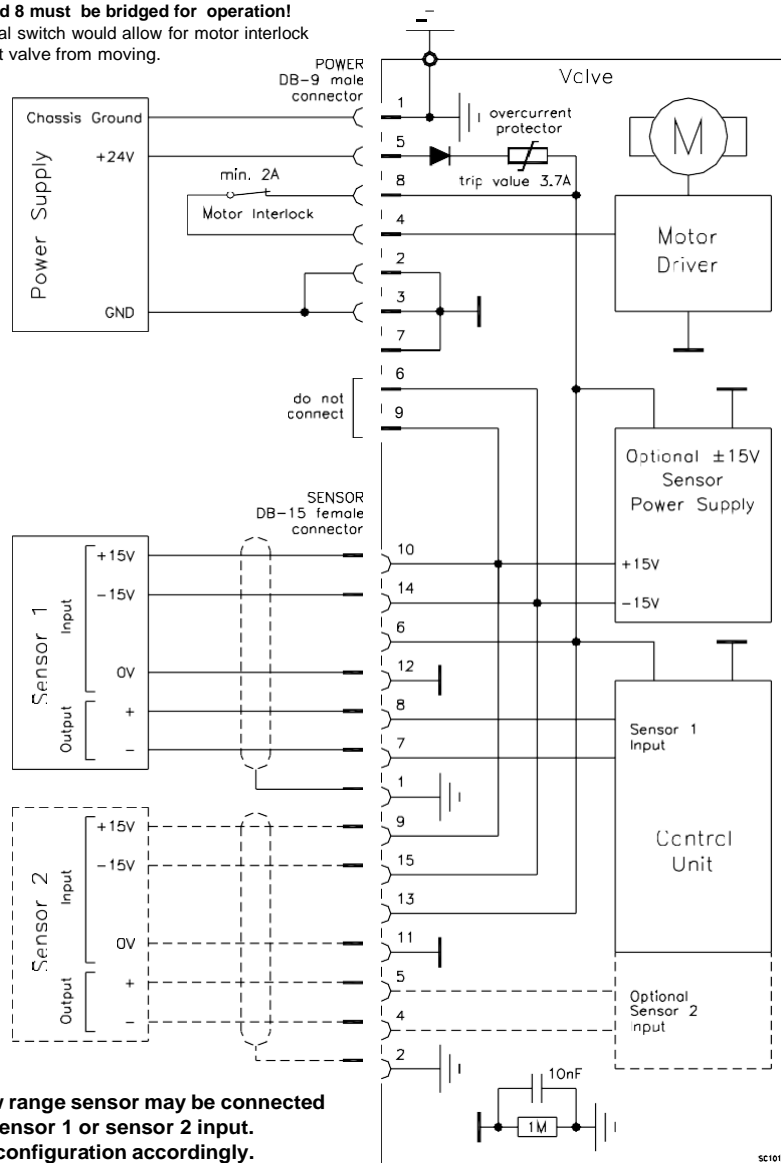

Note:

- Use shielded sensor cable(s). Keep cable as short as possible, but locate it away from noise sources.
- Connect the ± 15 VDC sensors at DB-15 female sensor connector exactly as shown in the drawing above. Do not connect other pins, that may damage power supply or controller!
- Connector: Use only screws with 4-40UNC thread for fastening the connectors!

2.6.5 RS232 interface connection

Refer to «Schematics» for wiring information.

2.6.6 Service port connection

The service port (connector: SERVICE) allows to connect the valve to a RS232 port of a computer. This requires a service cable and software from NOVASEN.

3 Operation



Operation is allowed after completion of the installation procedure only.

3.1 Introduction

This valve is designed for downstream pressure control in vacuum chambers. It can be employed in a pressure control mode or a position control mode. In both cases local or remote operation is possible.

3.1.1 Local operation

Local operation means that the valve is operated via the service port using a computer. When using a computer, a service cable and a software from VAT are required. You can either download our freeware 'Control View' or get our 'NOVASEN Control Performance Analyzer'.

These software are beneficial especially for setup, testing and maintenance.

How to start: Connect service cable, start software and push button 'LOCAL' to enable for operation. Then enter menu Setup/Sensor and do sensor configuration according to your application to make sure that you get the correct pressure displayed.

'Control view' supports:

- parameter setup
- manual control
- numeric monitoring
- basic diagnostic

'Control Performance Analyzer' supports:

- parameter setup
- manual control
- sequence control
- numeric and graphical monitoring
- data recording
- data analysis
- advanced diagnostic

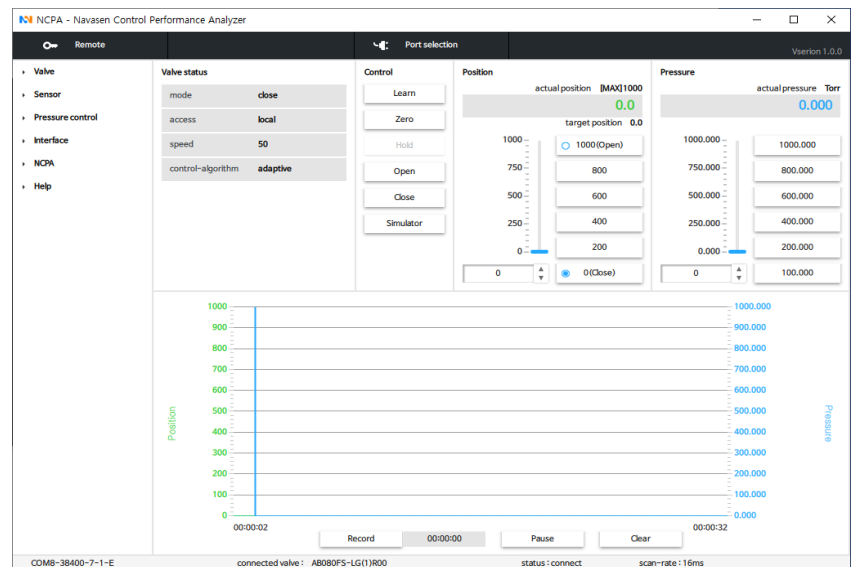

When communication to service port is interrupted the valve will change to remote operation. So when service cable will be disconnected or software will be shut down, the valve returns automatically to remote operation.

This may result in an immediate movement of the valve depending on remote control.

Refer to «Spare parts / Accessories» for ordering numbers of service cable, software and Service Box 2.

3.1.2 Remote operation

This product is equipped with a RS232 interface to allow for remote operation. See section «RS232 Interface» for details. 'Control View' software, 'Control Performance Analyzer' software or 'Service Box 2' may be used for monitoring during remote control.

Note: In case 'Control View' or 'Control Performance Analyzer' software is connected to valve make sure 'REMOTE' button is pushed to enable for remote operation. In case Service Box 2 is connected to valve make sure the LED on button 'LOCAL' is OFF for remote operation.

3.1.3 Safety mode

By means of an external switch (see connection diagrams «Electrical connection») the motor power supply can be interrupted. In this case the valve enters the 'safety mode'. This motor interlock prevents the valve from moving (e.g. maintenance work). Data reading from the control unit remains possible.

When motor interlock is active during power up the valve directly enters the 'safety mode' and is not able to synchronize. Display shows 'D C' or 'D999'. In this case synchronization cycle will be done when motor interlock is deactivated. Then Display shows 'INIT' for a moment followed by 'SYNC'.

When 'safety mode' is entered from operation (i.e. pressure control mode), the unit will automatically switch to position control mode and remain at current position. Once motor interlock is deactivated the unit remains in position control mode.

3.1.4 Service indication

This product is able to indicate that the valve unit needs to be cleaned, or an obstruction is present.

A service request is indicated when the control unit detects that motor steps are apparently not effective. This may happen when the valve unit is heavily contaminated. These 'lost' steps are recognized and will be repeated to attempt target position in the short term. But in the medium term the valve unit requires cleaning or inspection.

'Service request' (SR) would be indicated on the display or could be read via remote operation. Refer to «Display information» for details.

3.2 Operation under increased temperature

This valve may be operated in the temperature range mentioned in chapter «Technical data».

3.3 Behaviour during power up

Valve position before power up:	Reaction of valve:	
	Valve power up configuration = closed (default)	Valve power up configuration = open
Any	Valve runs a synchronization cycle (close-open-close) to detect the limit stops. This cycle is performed with reduced torque (2Nm). Display shows configuration of product until synchronization cycle is done. Refer also to chapter «Display information».	Valve position after power up is open



3.4 Behavior in case of power failure

Any	Valve remains at current position.	Valve will close or open depending on valve configuration *). Default is not defined. Display indicates F .
-----	------------------------------------	--

*) Provided that battery pack of the VAT controller is charged. Charging time after power up is 2 minutes max..

All parameters are stored in a power fail save memory.

3.5 Display information

There is a 4 digit display located on the panel. It displays configuration, status and position information. For details refer to following tables.

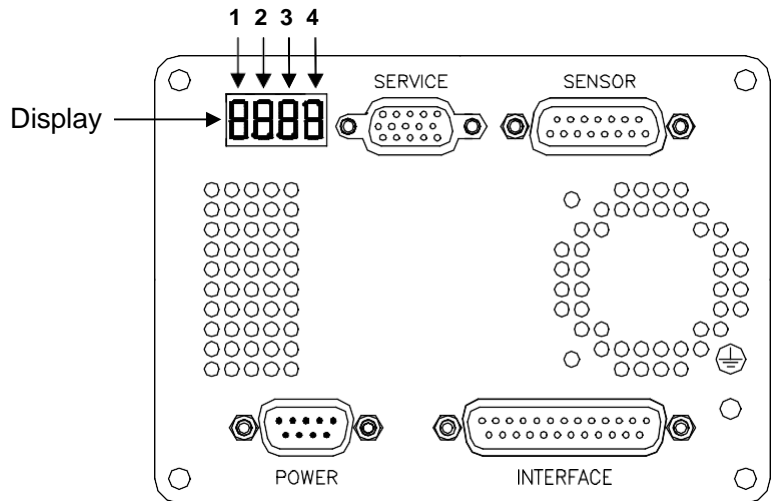

Power up:

Description	Digit 1	Digit 2	Digit 3	Digit 4
At first all dots are illuminated then configuration is displayed: <ul style="list-style-type: none"> • Firmware version [e.g. 1E00] (1st information for about 3s) • Controller configuration (2nd information for about 3s) In case D999 is displayed, motor interlock is active. Refer to «Safety mode» for details.	1	E	0	0
		2 = RS232 interface	0 = basic 1 = with SPS ¹⁾ 2 = with PFO ²⁾ 3 = with SPS ¹⁾ and PFO ²⁾	1 = 1 sensor version 2 = 2 sensor version
SYNC indicates that powerup synchronization is running.	S	Y	N	C

1) SPS = optional ±15 VDC Sensor Power Supply module

2) PFO = Power Failure Option

Operation:

Description / Mode	Digit 1	Digit 2	Digit 3	Digit 4
PRESSURE CONTROL mode	P	0 . . . 100 = valve position (% , 0 = closed / 100 = open)		
POSITION CONTROL mode	V			
Valve closed	C			
Valve open	O			
Closed / open interlock (Valve closed / open by digital input)	I			
HOLD (position frozen) activated	H			
ZERO running	Z			
LEARN running	L			
Safety mode established. Refer to «Safety mode» for details.	D			
Power failure	F			
Service request ¹⁾ (valve requires cleaning)				

¹⁾ If SR is blinking alternatively with the actual mode display (e.g. P.11 ⇔ ..SR) the valve requires cleaning.

Note: Rx/D / Tx/D activity of RS232 communication is displayed by 2 blinking dots in digit 2. The lower dot indicates Rx/D activity where the upper dot indicates Tx/D activity. The indication is not real time.

Fatal error:

Description	Digit 1	Digit 2	Digit 3	Digit 4
Fatal error occurred	E	Error code. Refer to «Trouble shooting» for details		

3.6 Setup procedure



To enable the valve for **pressure control** setup **steps 1 to 5 must be performed**. In case position control is required only it's sufficient to perform steps 1 to 3.

Setup step	Description
1	Power up Turn on external + 24VDC power supply of valve (and external ± 15 VDC for sensor power supply if required). Refer to chapter «Behavior during power up» for details.
2	Interface configuration RS232 parameters and digital inputs for valve may be changed from the default values. Refer to chapter «RS232 interface» for details.
3	Valve and sensor configuration Basic configurations of valve must be adapted according to application needs. Refer to chapter «Valve and sensor configuration» for details.
4	ZERO Compensation of the sensor offset voltage. Refer to chapter «ZERO» for details.
5	LEARN Determination of the vacuum system characteristic to accommodate the PID controller. Refer to chapter «LEARN» for details. Note: Without LEARN the valve is not able to run pressure control

3.6.1 Interface configuration

Interface configuration must be adapted according to application needs.

- RS232 baudrate, parity, data length and number of stop bits for valve must be selected.
- Functionality of digital interlock inputs CLOSE VALVE and OPEN VALVE. These may be configured as 'not inverted', 'inverted' or 'disabled'. Default is 'not inverted'. Refer also to «Digital inputs».
- Pressure and position range for RS232 communication must be selected. Default for pressure is 0 - 1'000'000. Default for position is 0 - 100'000.

Local operation: (‘Control View’, ‘Control Performance Analyzer’ or ‘Service Box 2’)	Remote operation: (Refer to chapter «Setup commands» for details)
Do configuration in menu ‘Setup / Interface’.	1. Send INTERFACE CONFIGURATION
	2. Send RANGE CONFIGURATION

3.6.2 Valve and sensor configuration

Basic valve configuration must be adapted according to application needs.

- Definition of valve plate position (CLOSE or OPEN) after power up sequence. Default is 'close'.
- Definition of valve plate position (CLOSE or OPEN) in case of a power failure. Default is 'not defined'.
- Only for versions that have Power Fail Option equipped [612 H ; 612 C].

- ZERO function: This may be 'disabled' or 'enabled'. Default is 'enabled'. Refer also to «ZERO».
- Sensor configuration for 2 sensor version [612 H]. Refer also to «Pressure control operation with 2 sensors».

Local operation: (‘Control View’, ‘Control Performance Analyzer’ or ‘Service Box 2’)	Remote operation: (Refer to chapter «setup commands» for details)
1. Do power up configuration in menu ‘Setup / Valve’.	1. Send VALVE CONFIGURATION
2. Do power fail configuration in menu ‘Setup / Valve’.	
3. Enable or disable ZERO function in menu ‘Setup / Sensor’.	2. Send SENSOR CONFIGURATION
4. Do sensor configuration in menu ‘Setup / Sensor’.	

3.6.3 ZERO

ZERO allows for the compensation of the sensor offset voltage.

When ZERO is performed the current value at the sensor input is equated to pressure zero. In case of a 2 sensor system both sensor inputs will be adjusted. A max. offset voltage of +/- 1.4 V can be compensated. The offset value can be read via local and remote operation.

Local operation: (‘Control View’, ‘Control Performance Analyzer’ or ‘Service Box 2’)	Remote operation: (Refer to chapter «control commands» resp. «setup commands» for details)
Go to menu ‘Zero / ZERO’ and follow instructions.	1. Send OPEN VALVE
	2. Wait until process chamber is evacuated and sensor signal is not shifting anymore.
	3. Send ZERO

Note: Do not perform ZERO as long as pressure gauge voltage is shifting otherwise incorrect pressure reading is the result. Refer to manual of sensor manufacturer for warm up time.

Note: Do not perform ZERO, if the base pressure of your vacuum system is higher than 1‰ of sensor full scale. We recommend disabling ZERO function in this case; refer to «Valve and sensor configuration» of the setup procedure. Otherwise incorrect pressure reading is the result.

3.6.4 LEARN

LEARN adapts the PID controller of the valve to the vacuum system and its operating conditions. LEARN must be executed only once during system setup.

The LEARN routine determines the characteristic of the vacuum system. Based on this, the PID controller is able to run fast and accurate pressure control cycles.

This characteristic depends on various parameters such as chamber volume, conductance and flow regime. Therefore it must be performed with a specific gas flow according to instruction below.

The result of LEARN is a pressure versus valve position data table. This table is used to adapt the PID parameters. The data table is stored in the device memory which is power fail save. The data table can be up-/downloaded via 'Control Performance Analyzer' software or remote interface. Due to encoding the data may not be interpreted directly.

By an OPEN VALVE, CLOSE VALVE, POSITION CONTROL or PRESSURE CONTROL command the routine will be interrupted.

Local operation: (‘Control View’, ‘Control Performance Analyzer’ or ‘Service Box 2’)	Remote operation: (Refer to chapter «RS232 control commands» resp. «RS232 setup commands» for details)
Go to ‘Learn / LEARN’ menu and follow instructions. Note: Gasflow calculation according to recommendation below is done automatically based on inputs.	<ol style="list-style-type: none"><li data-bbox="829 869 1399 902">1. Send OPEN VALVE<li data-bbox="829 902 1399 1021">2. Set specific gas flow according to calculation below and wait until flow is stable. LEARN does not need to be performed with the process gas. Instead N₂ or Ar may be used.<li data-bbox="829 1021 1399 1088">3. Send LEARN (with pressure limit set to full scale)

Note: Sensor signal must not shift during LEARN. Wait until sensor signal is stable before LEARN is performed.

Note: Learn may take several minutes. Do not interrupt the routine as **a single full run is required to ensure fast and accurate pressure control**. The PID controller covers 5% to 5000% of the gas flow which was used for learn.

Gasflow calculation for LEARN:



Do not apply a different gasflow for learn than determined below. Otherwise pressure control performance may be insufficient.

Note: Required pressure / flow regime must be known to calculate the most suitable learn gas flow for a specific application.

1. At first it is necessary to find out about the required control range respectively its conductance values. Each working point (pressure / flow) must be calculated with one following formulas. Choose the applicable formula depending on units you are familiar with.

$$C_{WP} = \frac{1000 \cdot q_{WP}}{p_{WP}}$$

C_{WP} required conductance of working point [l/s]
 q_{WP} **gasflow** of working point [**Pa m³/s**]
 p_{WP} **pressure** of working point [**Pa**]

$$C_{WP} = \frac{q_{WP}}{p_{WP}}$$

C_{WP} required conductance of working point [l/s]
 q_{WP} **gasflow** of working point [**mbar l/s**]
 p_{WP} **pressure** of working point [**mbar**]

$$C_{WP} = \frac{q_{WP}}{78.7 \cdot p_{WP}}$$

C_{WP} required conductance of working point [l/s]
 q_{WP} **gasflow** of working point [**scm**]
 p_{WP} **pressure** of working point [**Torr**]

2. Out of these calculated conductance values choose the lowest.

$$C_R = \min(C_{WP1}, C_{WP2}, \dots, C_{WPn})$$

C_R required lower conductance [l/s]
 C_{WPx} required conductance of working points [l/s]

Note: To make sure that the valve is capable to control the most extreme working point verify that $C_R \geq C_{min}$ of the valve (refer to «Technical data»).

3. Calculate gasflow for learn. Choose the applicable formula depending on units you are familiar with.

$$q_L = \frac{p_{max} \cdot C_R}{2000}$$

q_L gasflow for learn [**Pa m³/s**]
 p_{max} max. pressure to control [**Pa**]
 C_R required lower conductance [l/s]

$$q_L = \frac{p_{max} \cdot C_R}{2}$$

q_L gasflow for learn [**mbar l/s**]
 p_{max} max. pressure to control [**mbar**]
 C_R required lower conductance [l/s]

$$q_L = 39.4 \cdot p_{max} \cdot C_R$$

q_L gasflow for learn [**scm**]
 p_{max} max. pressure to control [**Torr**]
 C_R required lower conductance [l/s]

3.7 Close valve

Local operation: (‘Control View’, ‘Control Performance Analyzer’ or ‘Service Box 2’)	Remote operation: (Refer to chapter «RS232 control commands» for details)
Push CLOSE button	Send CLOSE VALVE

3.8 Open valve

Local operation: (‘Control View’, ‘Control Performance Analyzer’ or ‘Service Box 2’)	Remote operation: (Refer to chapter «RS232 control commands» for details)
Push OPEN button	Send OPEN VALVE

3.9 Position control

The valve position is directly controlled according to the position setpoint.

Local operation: (‘Control View’, ‘Control Performance Analyzer’ or ‘Service Box 2’)	Remote operation: (Refer to chapter «RS232 control commands» for details)
Select or enter position setpoint	Send POSITION CONTROL

3.10 Pressure control



To **prepare valve for PRESSURE CONTROL** perform complete «**Setup procedure**».

The valve has parameters that may be modified to tune **pressure control performance**. Refer to «**Tuning of control performance**».

The included PID controller controls the chamber pressure according to the pressure setpoint by means of the valve position. The PID controller works with an adaptive algorithm to achieve best results under altering conditions (gasflow, gas type).

Local operation: (‘Control View’, ‘Control Performance Analyzer’ or ‘Service Box 2’)	Remote operation: (Refer to chapter «RS232 control commands» for details)
Select or enter pressure setpoint	Send PRESSURE CONTROL

3.10.1 Operation with 2 sensors

If 2 sensor operation is enabled, changeover between the sensors is done automatically during pressure control. For configuration refer to chapter «Setup procedure». We recommend a ratio of 10:1 between the pressure gauges. Max. ratio is 100:1. It is required that the high range pressure gauge is connected to sensor 1 input and the low range pressure gauge to the sensor 2 input.

Between 90 and 100% of the low range sensor full scale, the low range sensor is phased out while high range sensor is phased in. This maintains a functional response behavior in case of small calibration errors between the two sensors. The pressure output in this range is a blend between both sensors.

For monitoring purpose each sensor signal may be read out individually.

Note: Make sure that both sensors are calibrated.

Note: Do not close optional gauge isolation valves during the transition phase between the sensors.

3.10.2 Tuning of control performance

Normally the default settings will result in good pressure control performance. For some applications tuning may be required to improve performance.

The tuning procedures for each parameter (grey boxes) and its default values are described separately below. Strictly keep the procedure order.

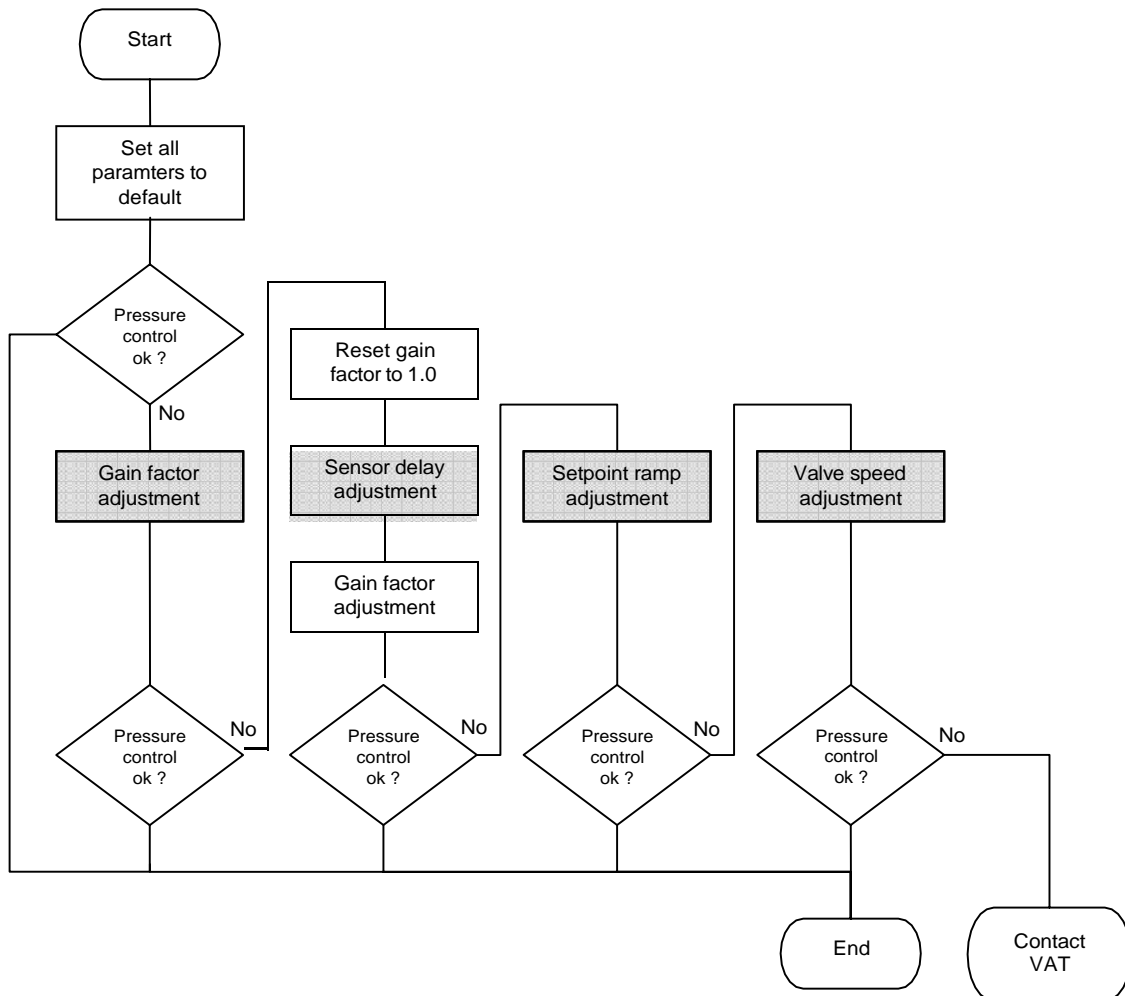

Required information for support:

- Go to 'Tools / Create Diagnostic File' in 'Control View' resp. 'Control Performance Analyzer' and save file
- Pressure / flow / gas conditions to be controlled
- Chamber volume
- Pumping speed (l/s) and pump type (e.g. turbo pump)
- System description
- Problem description

Send diagnostic file with and all required information to tuning-support@vat.ch

3.10.2.1 Gain factor adjustment

The gain factor effects:

- **Stability**
- **Response time**

Default value is 1. Adjustment range is from 0.0001 to 7.5.

Higher gain results in: faster response higher over- / undershoot of pressure
Lower gain results in: slower response lower over- / undershoot of pressure

Adjustment procedure:

1. Start with gain factor 1.0
2. Open valve.
3. Control a typical pressure / flow situation.
4. Repeat from step 2 with lower (higher) gain factors until optimal pressure response is achieved and stability is ok.

Note: Normally adjustments down to gain factors of 0.42 should lead to good results. Otherwise you may need to improve sensor connection. Refer to «Requirements to sensor connection».

Local operation: (‘Control View’, ‘Control Performance Analyzer’ or ‘Service Box 2’)	Remote operation: (Refer to chapter «setup commands» for details)
Set gain factor in menu ‘Setup / Control Parameter’	Send PID CONTROLLER CONFIGURATION

3.10.2.2 Sensor delay adjustment

Sensor delay adjustment effects:

- **Stability**

Default value is 0. Adjustment range is from 0 to 1.0s.

Pipes and orifices for sensor attachment delay response time and so badly impact pressure control stability. By adapting this parameter to the approximate delay time stability problems can be reduced. But control response time will be slowed down by this measure.

Note: Whenever possible sensors should be attached to the chamber according to «Requirements to sensor connection». This is the most effective measure against stability issues. If your gauge attachment fulfills these criteria do not use this parameter.

Adjustment procedure:

1. Start with gain factor 1.0 and sensor delay 0s.
2. Open valve.
3. Control a typical pressure / flow situation.
4. Repeat from step 2 with higher sensor delays until best possible stability is achieved.
5. Adjustment gain factor again. Refer to «Gain factor adjustment».

Local operation: (‘Control View’, ‘Control Performance Analyzer’ or ‘Service Box 2’)	Remote operation: (Refer to chapter «setup commands» for details)
Go to ‘Setup / Control Parameter’ menu. Select sensor delay.	Send PID CONTROLLER CONFIGURATION

3.10.2.3 Setpoint ramp adjustment

Setpoint ramp effects:

- Undershoot of pressure
- Response time

Default value for *Setpoint Ramp* is 0. Adjustment range for *Setpoint Ramp* is from 0 to 10 s.

This parameter defines the time that is used to decrease / raise pressure between 2 setpoints. Especially in pressure decrease situations at low flows pressure response can be improved much by adapting setpoint ramp time.

Pressure chart

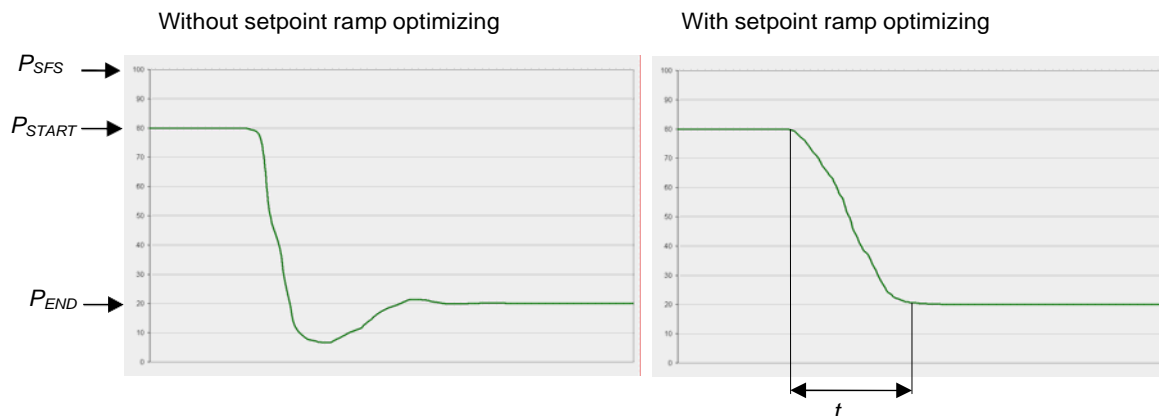

Choose the applicable formula depending on units you are familiar with.

$$t = \text{Setpoint Ramp}$$

Adjustment procedure:

1. Start with optimal gain factor and sensor delay time according to preceding tuning steps.
2. Control a typical pressure / flow situation.
3. Control a lower pressure.
4. Repeat from step 2 with longer setpoint ramps until best response is achieved.
5. Verify pressure control response for a setpoint raise situation.

Note: In case a long ramp time is required to get optimal performance for pressure decrease situations it may be of advantage to apply different settings for decrease / raise control situations.

Local operation: ('Control View', 'Control Performance Analyzer' or 'Service Box 2')	Remote operation: (Refer to chapter «setup commands» for details)
Go to 'Setup / Control Parameter' menu. Select setpoint ramp.	Send PID CONTROLLER CONFIGURATION

3.10.2.4 Valve speed adjustment

Valve speed effects:

- **Response time**

Default value is 1000. Adjustment range is from 1 to 1000.

This parameter effects valve plate actuating speed.

Speed adjustment is effective for PRESSURE CONTROL and POSITION CONTROL.

Note: Normally best pressure control response is achieved with max. valve speed. In particular applications it may be of advantage to have a slower valve response.

Note: OPEN and CLOSE are always done with max. speed.

Adjustment procedure:

1. Use optimal gain factor, sensor delay time and setpoint ramp according to preceding tuning steps.
2. Open valve.
3. Control a typical pressure / flow situation.
4. Repeat from step 2 with slower valve speed until required response is achieved.

Local operation: (‘Control View’, ‘Control Performance Analyzer’ or ‘Service Box 2’)	Remote operation: (Refer to chapter «setup commands» for details)
Go to ‘Setup / Control Parameter’ menu. Select valve speed.	Send VALVE SPEED

3.11 RS232 interface

3.11.1 Settings

The factory default setting of the RS232 interface might be changed to fit the application by using the Control View software, the Control Performance Analyzer software or the Service Box 2.

3.11.2 Schematics

This interface allows for remote operation by means of a command set based on the RS232 protocol. In addition there are 2 digital inputs and 2 digital outputs. Digital inputs may be operated either by switches or by voltage sources.



Active digital inputs have higher priority than RS232 commands.

a) Configuration with switches for digital inputs:

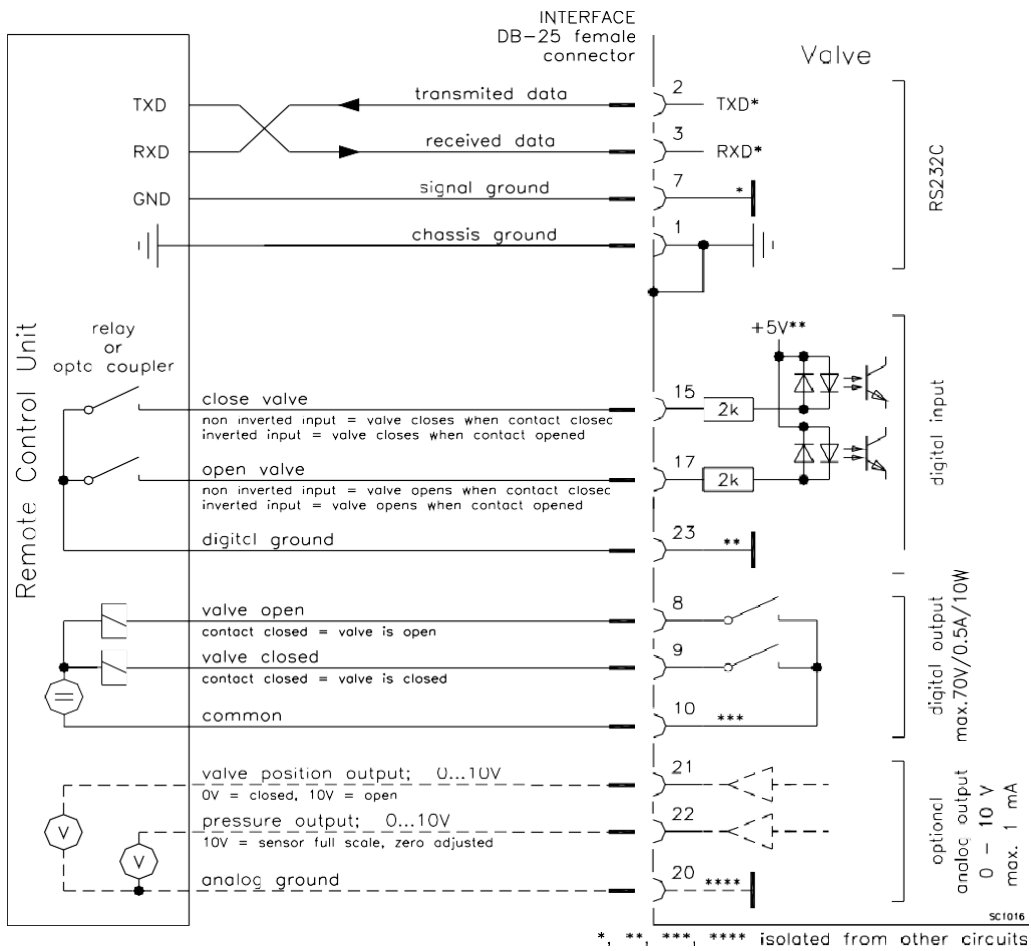

Note: Do not connect other pins than indicated in the schematics above!

Connector: Use only screws with 4-40UNC thread for fastening the DB-25 connector!

b) Configuration with voltage source for digital inputs:

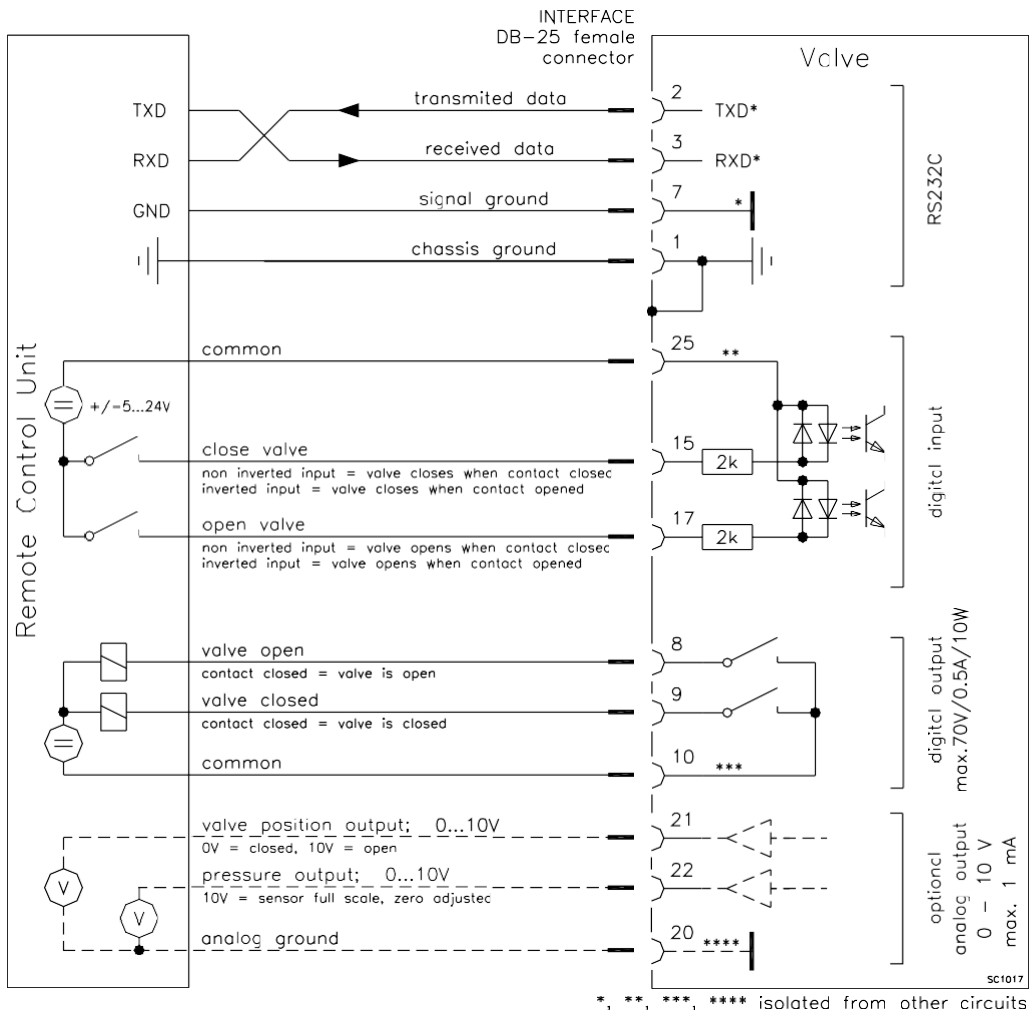

Note: Do not connect other pins than indicated in the schematics above!

Connector: Use only screws with 4-40UNC thread for fastening the DB-25 connector!

3.11.3 Digital inputs

Pin	Function	Signal type	Description	Priority
15	CLOSE VALVE	Digital input ¹⁾	<p>This function will close the valve. Valve will be in interlock mode as long as function is activated. After deactivation of function it will remain effective until</p> <ul style="list-style-type: none"> - OPEN valve digital input is active - converse RS232 control command have been received <p>The function is activated when optocoupler is 'on' in non inverted configuration.</p> <p>The function is activated when optocoupler is 'off' in inverted configuration.</p> <p>Configuration can be done in local operation via service port or in remote operation.</p>	1 ²⁾
17	OPEN VALVE	Digital input ¹⁾	<p>This function will open the valve. Valve will be in interlock mode as long as function is activated. After deactivation of function it will remain effective until converse RS232 control command have been received.</p> <p>The function is activated when optocoupler is 'on' in non inverted configuration.</p> <p>The function is activated when optocoupler is 'off' in inverted configuration.</p> <p>Configuration can be done in local operation via service port or in remote operation.</p>	2 ²⁾
23	DIGITAL GROUND	Digital ground	<p>Ground for all digital inputs. Ground is used when digital inputs are operated by switches. Connect switches to ground. See also «3.11.2 Schematics» configuration a).</p>	
25	DIGITAL COMMON	Digital common	<p>Common for all digital inputs. Common is used when digital inputs are driven by voltage sources. Connect + or – terminal of source with common (optocoupler inputs are capable of bidirectional operation). See also «3.11.2 Schematics» configuration b).</p>	

- 1) **All digital inputs are digitally filtered. Filter delay is 50ms. This means that digital signals must be applied for at least 50ms to be effective. Refer to «3.11.2 Schematics» for details about input circuit.**
- 2) **Highest priority is 1. Functions with lower priorities will not be effective as long as higher priority functions are active. These digital inputs have higher priority than all RS232 commands. RS232 commands will not be accepted while digital inputs are active.**

3.11.4 RS232 Command syntax

[function][value][CR][LF]

Each element is separated with square brackets for clarity. Square brackets are not part of command syntax. Unless otherwise specified all elements are ASCII characters. There are no spaces between the elements necessary. Commands and values are case sensitive.

Data length of value depends on command. Number of characters is specified in the description. Some commands do not require the value element.

[CR] is Carriage Return (0D hexadecimal). [LF] is Linefeed

3.11.5 Control commands

Control function	Command		Acknowledgement (within 10ms after reception of command)
	Description		
POSITION CONTROL	Set	[R:][xxxxxx][CR][LF]	[R:][CR][LF]
	Get	[i:38][CR][LF]	[i:38][00xxxxxx][CR][LF]
	xxxxxx	data length 6 characters for writing 8 characters starting with double zero for reading position SETPOINT, value depends on configuration, refer to «RS232 setup commands, RANGE CONFIGURATION» for details Change to POSITION CONTROL mode and transfer of position SETPOINT value resp. reading of position SETPOINT. Note: Reading returns position setpoint only in case pressure control is not selected.	
PRESSURE CONTROL	Set	[S:][0xxxxxxx][CR][LF]	[S:][CR][LF]
	Get	[i:38][CR][LF]	[i:38][0xxxxxxx][CR][LF]
	xxxxxxx	data length 8 characters starting with a zero pressure SETPOINT, value depends on configuration, refer to «RS232 setup commands, RANGE CONFIGURATION» for details Change to PRESSURE CONTROL mode and transfer of pressure SETPOINT resp. reading of pressure SETPOINT. Note: Reading returns pressure setpoint only in case pressure control is selected, otherwise position setpoint is returned.	
HOLD	Set	[H:][CR][LF]	[H:][CR][LF]
	This function stops the valve at the current position. It is effective in PRESSURE CONTROL and POSITION CONTROL. The function can be revoked by a POSITION CONTROL, PRESSURE CONTROL, OPEN VALVE or CLOSE VALVE command.		
CLOSE VALVE	Set	[C:][CR][LF]	[C:][CR][LF]
	Valve will close.		
OPEN VALVE	Set	[O:][CR][LF]	[O:][CR][LF]
	Valve will open.		

3.11.6 Inquiry commands

Inquiry function	Command		Acknowledgement (within 10ms after reception of command)
	Description		
ASSEMBLY	Get	[i:76][CR][LF]	[i:76][xxxxxxsyyyyyyabc][CR][LF]
	<p>data length 17 characters</p> <p>xxxxxx position, return value depends on configuration, refer to «RS232 setup commands, RANGE CONFIGURATION» for details</p> <p>s sign, 0 for positive pressure readings, - for negative pressure readings</p> <p>yyyyyy pressure, return value depends on configuration, refer to «RS232 setup commands, RANGE CONFIGURATION» for details</p> <p>a 0 = local operation, 1 = remote operation, 2 = locked remote operation</p> <p>b 0 = Initialization (Refer to chapter: «Behavior during power up» 1 = synchronization, 2 = POSITION CONTROL, 3 = CLOSED 4 = OPEN, 5 = PRESSURE CONTROL, 6 = HOLD , 7 = LEARN 8 = INTERLOCK (OPEN by digital input) 9 = INTERLOCK (CLOSED by digital input) C = power failure, D = safety mode E = fatal error (read «FATAL ERROR STATUS» for details)</p> <p>c 0 = no warning, 1 = warning present (read «WARNINGS» and «ERROR STATUS» for details)</p> <p>This function returns an assembly consisting of POSITION, PRESSURE and main status information for the valve.</p>		
POSITION	Get	[A:][CR][LF]	[A:][xxxxxx][CR][LF]
	<p>data length 6 characters</p> <p>xxxxxx position, return value depends on configuration, refer to «RS232 setup commands, RANGE CONFIGURATION» for details</p> <p>This function returns the current valve position.</p> <p>Note: When motor interlock is active during power up the valve enters the 'safety mode' and is not able to recognize position. In this case position 999'999 is returned.</p>		
PRESSURE	Get	[P:][CR][LF]	[P:][sxxxxxx][CR][LF]
	<p>data length 8 characters</p> <p>s sign, 0 for positive readings, - for negative readings</p> <p>xxxxxx pressure, return value depends on configuration, refer to «RS232 setup commands, RANGE CONFIGURATION» for details</p> <p>This function returns the actual pressure.</p>		

Inquiry function	Command	Acknowledgement (within 10ms after reception of command)
	Description	
SENSOR 1 READING	Get	[[i:64][CR][LF]
		[[i:64][sxxxxxxx][CR][LF]
	<p>data length 8 characters</p> <p>s sign, 0 for positive readings, - for negative readings</p> <p>xxxxxxx sensor 1 reading, return value depends on configuration, refer to «RS232 setup commands, RANGE CONFIGURATION» for details</p> <p>This function returns direct reading from sensor 1 input.</p>	
SENSOR 2 READING	Get	[[i:65][CR][LF]
		[[i:65][sxxxxxxx][CR][LF]
	<p>data length 8 characters</p> <p>s sign, 0 for positive readings, - for negative readings</p> <p>xxxxxxx sensor 2 reading, return value depends on configuration, refer to «RS232 setup commands, RANGE CONFIGURATION» for details</p> <p>This function returns direct reading from sensor 2 input.</p>	
PRESSURE CONTROL STATUS	Get	[[i:36][CR][LF]
		[[i:36][abcdefgh][CR][LF]
	<p>data length 8 characters</p> <p>a 0 = no pressure control (e.g. if position control is selected) 1 = wide range control (PD control) 2 = close up control (PID control)</p> <p>cdefgh reserved, do not use</p> <p>The controller distinguishes 2 control ranges and acts accordingly.</p>	
DEVICE STATUS	Get	[[i:30][CR][LF]
		[[i:30][abcdefgh][CR][LF]
	<p>data length 8 characters</p> <p>a 0 = local operation, 1 = remote operation, 2 = locked remote operation</p> <p>b 0 = Initialization (Refer to chapter: «Behavior during power up» 1 = synchronization, 2 = POSITION CONTROL, 3 = CLOSED 4 = OPEN, 5 = PRESSURE CONTROL, 6 = HOLD, 7 = LEARN 8 = INTERLOCK (OPEN by digital input) 9 = INTERLOCK (CLOSED by digital input) C = power failure, D = safety mode E = fatal error (read «FATAL ERROR STATUS» for details)</p> <p>c 0 = Power Failure Option (PFO) disabled 1 = Power Failure Option (PFO) enabled</p> <p>d 0 = no warning, 1 = warning present (read «WARNINGS» and «ERROR STATUS» for details)</p> <p>efg reserved, do not use</p> <p>h 0 = normal operation, 1 = simulation running</p> <p>This function returns status information about the valve.</p> <p>Note: In simulation mode the valve can demonstrate pressure control capability independent of other equipment such as vacuum chamber, flow controller and gauge. Normal operation is not possible when simulation is running.</p>	

Inquiry function	Command		Acknowledgement (within 10ms after reception of command)
	Description		
WARNINGS	Get	[i:51][CR][LF]	[i:51][abcdefgh][CR][LF]
	<p>data length 8 characters</p> <p>a 0 = no service required 1 = service request, it is indicated when the control unit detects that motor steps are apparently not effective. This may happen when the valve is heavily contaminated or the gate seal is heavily sticking. These 'lost' steps are recognized and will be repeated to attempt target position in the short term. But in the medium term the valve requires cleaning or inspection.</p> <p>b 0 = LEARN data set present, 1 = LEARN data set not present</p> <p>c 0 = power failure battery ready 1 = power failure battery not ready</p> <p>defgh reserved, do not use</p> <p>This function returns warning information about the valve. If a warning is present countermeasure should be taken. Use RESET command to delete service request bit. Note: Without LEARN the valve is not able to run pressure control</p>		
SENSOR OFFSET	Get	[i:62][CR][LF]	[i:62][aaaabbbb][CR][LF]
	<p>data length 8 characters</p> <p>aaaa offset sensor 1 (-140 ... 0140 = -1.40V ... +1.40V)</p> <p>bbbb offset sensor 2 (-140 ... 0140 = -1.40V ... +1.40V)</p> <p>This function returns the sensor offset voltages for both sensors (adjusted by ZERO).</p>		
SENSOR 1 OFFSET	Get	[i:60][CR][LF]	[i:60][xxxxxxx][CR][LF]
	<p>data length 8 characters</p> <p>xxxxxxx offset sensor 1 (-1400000 ... 01400000 = -1.400000V ... +1.400000V)</p> <p>This function returns the sensor 1 offset voltage (adjusted by ZERO).</p>		
SENSOR 2 OFFSET	Get	[i:61][CR][LF]	[i:61][xxxxxxx][CR][LF]
	<p>data length: 8 characters</p> <p>xxxxxxx offset sensor 2 (-1400000 ... 01400000 = -1.400000V ... +1.400000V)</p> <p>This function returns the sensor 2 offset voltage (adjusted by ZERO).</p>		

Inquiry function	Command		Acknowledgement (within 10ms after reception of command)
	Description		
LEARN STATUS	Get	[[i:32][CR][LF]	[[i:32][abcdefgh][CR][LF]
	<p>data length 8 characters</p> <p>a 0 = LEARN not running, 1 = LEARN running</p> <p>b 0 = LEARN data set present, 1 = LEARN data set not present</p> <p>c 0 = ok</p> <p> 1 = last LEARN interrupted by user (control command)</p> <p> 2 = last LEARN interrupted by control unit (valve open pressure > sensor full scale)</p> <p>d 0 = ok</p> <p> 1 = valve open pressure > 50% sensor full scale (gasflow too high)</p> <p> 2 = valve open pressure < 0 (sensor offset present)</p> <p>e 0 = ok</p> <p> 1 = valve max. throttle pressure < 10% sensor full scale (gasflow too low)</p> <p>f 0 = ok</p> <p> 1 = pressure not raising during LEARN (gasflow missing)</p> <p>g 0 = ok</p> <p> 1 = sensor unstability during LEARN</p> <p>h reserved, do not use</p> <p>This function checks the status of LEARN and indicates if the conditions during LEARN were ok.</p>		
LEARN PRESSURE LIMIT	Get	[[i:34][CR][LF]	[[i:34][0xxxxxxx][CR][LF]
	<p>data length 8 characters starting with a zero</p> <p>xxxxxxx pressure limit for LEARN, return value depends on configuration, refer to «RS232 setup commands, RANGE CONFIGURATION» for details</p> <p>This function returns the pressure limit applied for LEARN.</p>		
ERROR STATUS	Get	[[i:52][CR][LF]	[[i:52][abcdefgh][CR][LF]
	<p>data length 8 characters</p> <p>a reserved, do not use</p> <p>b 1 = sensor 1 signal converter failure</p> <p>c reserved, do not use</p> <p>d 1 = firmware memory failure</p> <p>efgh reserved, do not use</p> <p>This function returns an error code in case of any malfunction of the device otherwise 0 is returned.</p>		
FATAL ERROR STATUS	Get	[[i:50][CR][LF]	[[i:50][abc][CR][LF]
	<p>data length 3 characters</p> <p>abc error code = 000 (no error) or 020 (E:20) or 022 (E:22) or 040 (E:40)</p> <p>See in chapter «Trouble shooting» for details.</p> <p>This function returns an error code in case of any malfunction of the device.</p>		

3.11.7 Setup commands

Setup function	Command		Acknowledgement (within 10ms after reception of command)
	Description		
ACCESS MODE	Set	[c:01][xx][CR][LF]	[c:01][CR][LF]
	<p>data length: 2 characters</p> <p>xx 00 = local operation (service port) 01 = remote operation, change to local enabled 02 = locked remote operation, change to local not possible via service port</p> <p>This function selects the access authorization to the valve. To read access mode use inquiry command DEVICE STATUS.</p> <p>Note: Local operation is only possible when either 'Control View' or 'Control Performance Analyzer' software is running. When communication to service port is interrupted the valve will automatically change to remote operation.</p>		
INTERFACE CONFIGURATION	Set	[s:20][abcdefgh][CR][LF]	[s:20][CR][LF]
	Get	[i:20][CR][LF]	[i:20][abcdefgh][CR][LF]
<p>data length 8 characters</p> <p>a baud rate: 0 = 600, 1 = 1200k, 2 = 2400, 3 = 4800, 4 = 9600 5 = 19.2k, 6 = 38.4k, 7 = 57.6k, 8 = 115.2k</p> <p>b parity bit: 0 = even, 1 = odd, 2 = mark, 3 = space, 4 = no</p> <p>c data length: 0 = 7 bit, 1 = 8 bit</p> <p>d number of stop bits: 0 = 1, 1 = 2</p> <p>e 0 (reserved, do not change)</p> <p>f digital input OPEN VALVE: 0 = not inverted, 1 = inverted, 2 = disabled</p> <p>g digital input CLOSE VALVE: 0 = not inverted, 1 = inverted, 2 = disabled</p> <p>h 0 (reserved, do not change)</p> <p>This function does the RS232 and digital input configuration.</p> <p>Note: Digital outputs are always enabled.</p>			
VALVE CONFIGURATION	Set	[s:04][abcdefgh][CR][LF]	[s:04][CR][LF]
	Get	[i:04][CR][LF]	[i:04][abcdefgh][CR][LF]
<p>data length 3 characters</p> <p>a valve position after power up: 0 = closed, 1 = open</p> <p>b valve position after power failure: 0 = closed, 1 = open</p> <p>c 0 (reserved, do not change)</p> <p>d 0 (reserved, do not change)</p> <p>e 0 (reserved, do not change)</p> <p>f 0 (reserved, do not change)</p> <p>g 0 (reserved, do not change)</p> <p>h 0 (reserved, do not change)</p> <p>This function does the valve configuration.</p>			

Setup function	Command		Acknowledgement (within 10ms after reception of command)
	Description		
SENSOR CONFIGURATION	Set	[s:01][abcdefgh][CR][LF]	[s:01][CR][LF]
	Get	[i:01][CR][LF]	[i:01][abcdefgh][CR][LF]
	<p>data length 8 characters</p> <p>a 0 = no sensor 1 = 1 sensor operation (sensor 1 input) 2 = 2 sensor operation with automatic changeover (low range = sensor 2 input, high range = sensor 1 input) 3 = 1 sensor operation (sensor 2 input) 4 = 2 sensor operation with automatic changeover (low range = sensor 1 input, high range = sensor 2 input)</p> <p>Note: Sensor operation modes 2, 3 and 4 are possible with 2 sensor hardware (612 H - and 612 W) only.</p> <p>Note: For applications where the high range sensor is used for for monitoring purpose only, select sensor operation modes 1 or 3 for pressure control with low range sensor and read high range sensor from «SENSOR 2 READING» resp. «SENSOR 1 READING».</p> <p>b 1 = ZERO enabled, 0 = ZERO disabled</p> <p>cdefgh High range / Low range sensor full scale ratio * 1'000 (1000 ... 100000). In case of a 1 sensor valve use any value within the valid range.</p> <p>This function does the sensor configuration <u>for pressure control</u>.</p>		

Setup function	Command		Acknowledgement (within 10ms after reception of command)
	Description		
RANGE CONFIGURATION	Set	[s:21][abcdefgh][CR][LF]	[s:21][CR][LF]
	Get	[i:21][CR][LF]	[i:21][abcdefgh][CR][LF]
	<p>data length 8 characters</p> <p>a range for POSITION: 0 = 0 – 1'000, 1 = 0 – 10'000, 2 = 0 – 100'000</p> <p>bcdefgh upper value for PRESSURE and SENSOR READING: 1000 ... 1000000 e.g. 0010000 -> pressure range 0 – 10'000</p> <p>This function defines the communication range between the valve and the host computer for POSITION, PRESSURE and SENSOR READING.</p> <p>Note: In case ZERO has been performed, gauge offset for PRESSURE and SENSOR READING is compensated.</p> <p>Note: In case 2 sensor operation for pressure control is selected, PRESSURE covers high range gauge because switchover between sensors is done automatically.</p> <p>SENSOR 1 READING and SENSOR 2 READING always return full scale values according to selected range.</p>		

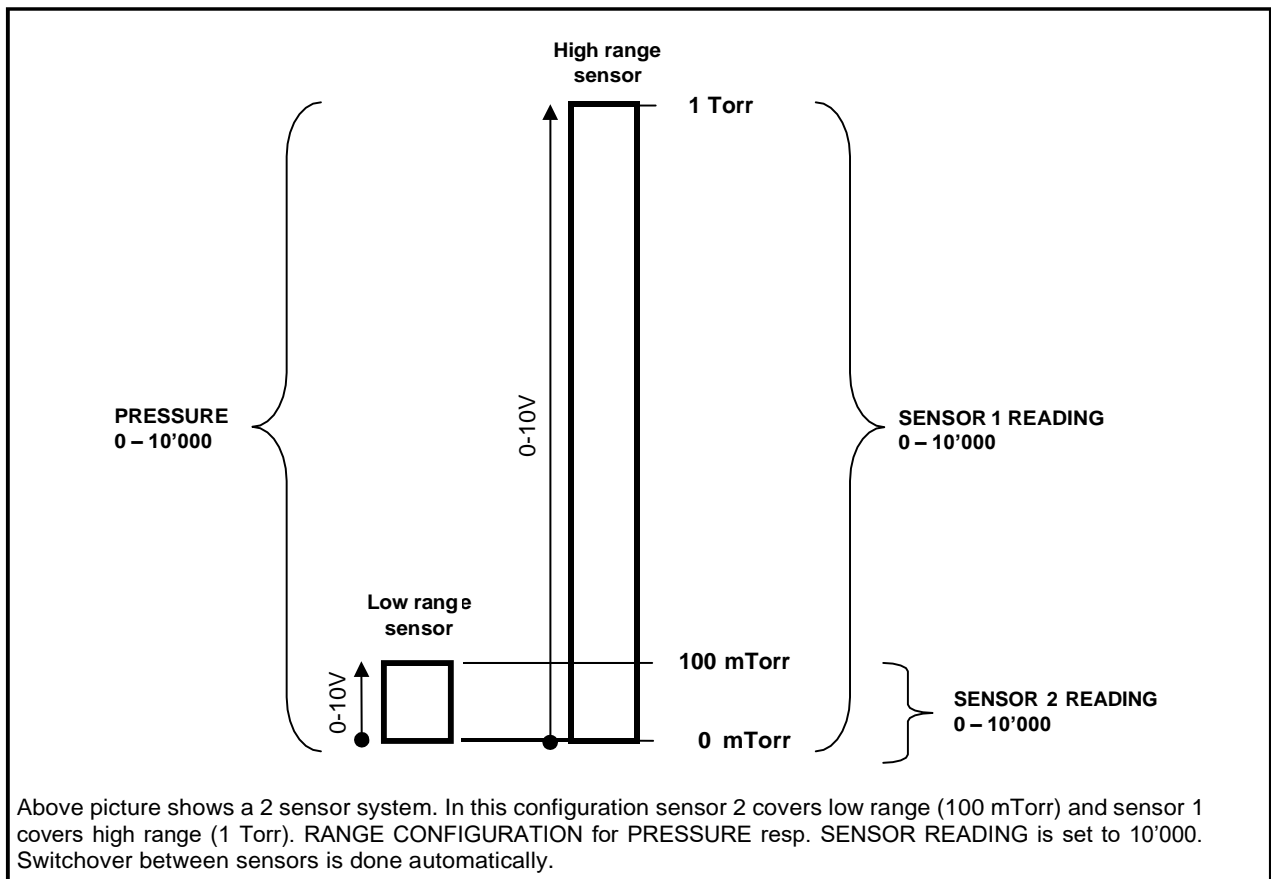

Setup function	Command		Acknowledgement (within 10ms after reception of command)
	Description		
ZERO	Set	[Z:][CR][LF]	[Z:][CR][LF]
	This command initiates ZERO to compensate for offset of gauge(s). Note: Refer to «ZERO» for correct zero procedure.		
PRESSURE ALIGNMENT	Set	[c:6002][xxxxxxx][CR][LF]	[c:60][CR][LF]
	data length: 8 characters xxxxxxx System base pressure, value depends on configuration, refer to «RS232 setup commands, RANGE CONFIGURATION» for details. Alignment range is equivalent to max. +/-1.4V sensor signal. This command aligns PRESSURE to a certain value. Also SENSOR READING will be aligned accordingly. It might be used instead of ZERO in case base pressure is not low enough.		
LEARN	Set	[L:][0xxxxxx][CR][LF]	[L:][CR][LF]
	data length 8 characters starting with a zero xxxxxxx Pressure limit for LEARN, value depends on configuration, refer to «RS232 setup commands, RANGE CONFIGURATION» for details This command starts LEARN. By OPEN VALVE, CLOSE VALVE or POSITION CONTROL commands the routine may be interrupted. Note: Without LEARN the PID controller is not able to perform pressure control. Refer to «LEARN» for correct learn gas flow and procedure.		
DOWNLOAD LEARN DATA	Set	[d:][pppdddddd][CR][LF]	[d:][ppp][CR][LF]
	data length 3 + 8 characters ppp pointer, 000 ... 103 ddddddd single data set This command downloads the LEARN data sets from the host computer to the valve. There are a total number of 104 data sets. Each data set consists of 8 data bytes and needs to be uploaded separately. Note: Make sure that all 104 data sets will be downloaded.		
UPLOAD LEARN DATA	Get	[u:][ppp][CR][LF]	[u:][pppdddddd][CR][LF]
	data length 3 + 8 characters ppp pointer, 000 ... 103 ddddddd single data set This command uploads the LEARN data sets from the valve up to the host. There are a total number of 104 data sets. Each data set consists of 8 data bytes and needs to be uploaded separately. Note: Make sure that all 104 data sets will be uploaded.		

Setup function	Command		Acknowledgement (within 10ms after reception of command)
	Description		
PID CONTROLLER CONFIGURATION	Set	[s:02][abcdefgh][CR][LF]	[s:02][CR][LF]
	Get	[i:02][CR][LF]	[i:02][abcdefgh][CR][LF]
	<p>data length 8 characters</p> <p>a 0 (reserved, do not change)</p> <p>b gain factor: 0 = 0.10, 1 = 0.13, 2 = 0.18, 3 = 0.23, 4 = 0.32, 5 = 0.42, 6 = 0.56 7 = 0.75, 8 = 1.00, 9 = 1.33, A = 1.78, B = 2.37, C = 3.16, D = 4.22 E = 5.62, F = 7.50, G = 0.0001, H = 0.0003, I = 0.001, J = 0.003, K = 0.01, L = 0.02, M = 0.05</p> <p>c sensor delay: 0 = 0.00, 1 = 0.02, 2 = 0.04, 3 = 0.06, 4 = 0.08, 5 = 0.10, 6 = 0.15, 7 = 0.20, 8 = 0.25, 9 = 0.30, A = 0.35, B = 0.4, C = 0.50, D = 0.60, E = 0.80, F = 1.00</p> <p>d setpoint ramp: 0 = 0.0, 1 = 0.5, 2 = 1.0, 3 = 1.5, 4 = 2.0, 5 = 2.5, 6 = 3.0, 7 = 3.5, 8 = 4.0, 9 = 4.5, A = 5.0, B = 5.5, C = 6.0, D = 6.5, E = 7.0, F = 7.5, G = 8.0, H = 8.5, I = 9.0, J = 9.5, K = 10.0</p> <p>efgh 0000 (reserved, do not change)</p> <p>This command selects gain factor, sensor response time and setpoint ramp for the PID controller.</p> <p>Note: Refer to «Tuning of control performance» for details.</p>		
VALVE SPEED	Set	[V:][00xxxx][CR][LF]	[V:][CR][LF]
	Get	[i:68][CR][LF]	[i:68][0000xxxx][CR][LF]
	<p>data length 6 characters starting with double zero for writing 8 characters starting with quadruple zero for reading</p> <p>xxxx valve speed, 1 ... 1000 (1 = min. speed, 1000 = max. speed)</p> <p>This command allows changing the actuating speed of the valve plate. Speed selection is effective for pressure control and position control. Open valve and close valve are always done with max. speed.</p> <p>Note: Refer to «Valve speed adjustment» for details.</p>		
RESET	Set	[c:82][xx][CR][LF]	[c:82][CR][LF]
	<p>data length 2 characters</p> <p>xx 00 = reset service request bit from WARNINGS 01 = reset FATAL ERROR (restart control unit)</p> <p>This function resets warnings and errors.</p>		

3.11.8 Error messages

Description	Error message
Protocol	
Parity error	[E:][000001][CR][LF]
Framing error (data length, number of stop bits)	[E:][000003][CR][LF]
Input buffer overflow (to many characters)	[E:][000002][CR][LF]
Commands	
<CR> or <LF> missing	[E:][000010][CR][LF]
: missing	[E:][000011][CR][LF]
Unknown command	[E:][000020][CR][LF] [E:][000021][CR][LF]
Invalid value	[E:][000022][CR][LF] [E:][000023][CR][LF]
Value out of range	[E:][000030][CR][LF]
Invalid number of characters (between : and [CR][LF])	[E:][000012][CR][LF]
Setup	
ZERO disabled	[E:][000060][CR][LF]
Device Status	
Command not accepted due to local operation	[E:][000080][CR][LF]
Command not accepted due to synchronization, CLOSED or OPEN by digital input, safety mode or fatal error	[E:][000082][CR][LF]
Hardware	
Command not applicable for hardware configuration	[E:][000041][CR][LF]

4 Trouble shooting

Failure	Check	Action
No dots lighted on display	24 V power supply ok?	Connect valve to power supply according to «Electrical connection» and make sure that power supply is working.
Remote operation does not work	<ul style="list-style-type: none"> - Local operation via service port active - Safety mode active, check for D on display? 	<ul style="list-style-type: none"> - Switch to remote operation. - Provide power to motor to allow for operation. - Refer to «Electrical connection» for details.
Display shows «E 20»and position is 009999 (fatal error - limit stop of valve unit not detected)	Clamp coupling screw not fastened?	Tighten screw. Refer to «Tightening torque» for details. RESET or restart of valve is necessary.
Display shows «E 21»and position is 009999 (fatal error - rotation angle of valve plate limited during power up)	<ul style="list-style-type: none"> - Valve plate centric adjusted? - Valve unit heavy contaminated? - Valve plate mechanically obstructed? 	<ul style="list-style-type: none"> - Adjust valve plate according to «Maintenance procedure». - Clean valve unit according to «Maintenance procedure». - Resolve obstruction. - Reset control unit. Cycle power (OFFàON) <p>or</p> <ul style="list-style-type: none"> - Send reset command: local via service port with CV/CPA/Service Box2
Display shows «E 22»and position is 009999 (fatal error - rotation angle of valve plate limited during operation)	<ul style="list-style-type: none"> - Valve unit heavy contaminated? - Valve plate mechanically obstructed? 	<ul style="list-style-type: none"> - Clean valve unit according to «Maintenance procedure». - Resolve obstruction. - Reset control unit. Cycle power (OFFàON) <p>or</p> <ul style="list-style-type: none"> - Send reset command: local via service port with CV/CPA/Service Box2
Display shows «E 40»and position is 009999 (fatal error - motor driver failure detected)		Replace control and actuating unit according to «Maintenance procedure».
Display shows «D 0» Motor Interlock is open	Motor power supplied?	<ul style="list-style-type: none"> - Provide power to motor to allow for operation. - Refer to «Electrical connection» for details.

Failure	Check	Action
Display shows «SR» (Service Request)	Valve unit heavy contaminated? Or gate seal is sticking.	<ul style="list-style-type: none"> - Clean valve unit according to «Maintenance procedures». - Reset control unit. Cycle power (OFFàON) or <ul style="list-style-type: none"> - Send reset command: local via service port with CV/CPA/Service Box2
CLOSE VALVE does not work	<ul style="list-style-type: none"> - Safety mode active, check for D on display? - Maintenance mode active 	<ul style="list-style-type: none"> - Provide power to motor to allow for operation. - Refer to «Electrical connection» for details. - Refer to “Display shows «M C»” in this table
OPEN VALVE does not work	<ul style="list-style-type: none"> - Safety mode active, check for D on display? - Maintenance mode active 	<ul style="list-style-type: none"> - Provide power to motor to allow for operation. Refer to «Electrical connection» for details. - Refer to “Display shows «M100»” in this table
Display shows «M C» Maintenance mode active		<p>Pin 14 of service connector is connected to ground. Plate will close. Further movement of plate is blocked.</p> <p>Note: Priority of pin 14 is higher than pin 13. If pin 14 is connected to ground after pin 13 the valve will close.</p> <p>Ground of service connector is at pin 4 and 8.</p>
Display shows «M100» Maintenance mode active		<p>Pin 13 of service connector is connected to ground. Plate will open. Further movement of plate is blocked.</p>
Pressure reading is wrong or pressure reading is negative	<ul style="list-style-type: none"> - Sensor(s) connected? - 2 sensor version present at valve controller? - ZERO done? - Does sensor power supply provide enough power for sensor(s)? 	<ul style="list-style-type: none"> - Refer to «Electrical connection». - Check valve version on page 1. Verify configuration. Refer to «Setup procedure». - Perform ZERO when base pressure is reached. Refer to «ZERO» for details. - Verify sensor supply voltage.
ZERO does not work	<ul style="list-style-type: none"> - Valve in open position, check for O on display? - ZERO disabled? 	<ul style="list-style-type: none"> - OPEN VALVE and bring chamber to base pressure before performing ZERO. - Enable ZERO. Refer to «Valve configuration» for details.

Failure	Check	Action
Pressure is not '0' after ZERO	<ul style="list-style-type: none"> - Sensor voltage shifting? - System pumped to base pressure? - Sensor offset voltage exceeds $\pm 1.4V$ 	<ul style="list-style-type: none"> - Wait until sensor does not shift any more before performing ZERO. - OPEN VALVE and bring chamber to base pressure before performing ZERO. - Replace pressure gauge.
PRESSURE CONTROL does not work	<ul style="list-style-type: none"> - Safety mode active, check for D on display? - PRESSURE CONTROL selected, check for P on display? - LEARN done? 	<ul style="list-style-type: none"> - Provide power to motor to allow for operation. Refer to «Electrical connection» for details. - Select PRESSURE CONTROL mode. Refer to «Pressure control» for details. - Perform LEARN. Refer to «Setup procedure» for details.
PRESSURE CONTROL not optimal	<ul style="list-style-type: none"> - Setup done completely? - LEARN done? - ZERO performed before LEARN? - LEARN interrupted? - Was gas flow stable during LEARN? - Tuning done? - Is sensor range suited for application? - Noise on sensor signal? 	<ul style="list-style-type: none"> - Perform «Setup procedure» completely. - Perform LEARN. Refer to «LEARN» for details. - Perform ZERO then repeat LEARN. Refer to «Setup procedure» for details. - Repeat LEARN. Refer to «LEARN» for details. - Repeat LEARN with stable gas flow. Refer to «LEARN» for details. - Tune valve for application. Refer to «Tuning of control performance» for details. - Use a sensor with suitable range (controlled pressure should be $>3\%$ and $< 98\%$ of sensor full scale). - Make sure a shielded sensor cable is used.

If you need any further information, please contact one of our service centers. You can find the addresses on our website: <http://www.vat.ch>

5 Maintenance & repairs

Under clean operating conditions, the valve does not require any maintenance during the specified cycle life. Contamination from the process may influence the function and requires more frequent maintenance.

Before carrying out any maintenance or repairs, please contact NOVASEN. It has to be individually decided whether the maintenance/repair can be performed by the customer or has to be carried out by NOVASEN.

All supplies (e. g. compressed air, electrical power) must be disconnected for removal/installation of the valve from/into the system.



Even with disconnected supply, loaded springs and/or air cushions in cylinders can be potential hazards.



Keep fingers and objects away from the valve opening!

Products returned to VAT must be free of harmful substances such as e.g. toxic, caustic or micro-biological ones. If products are radioactively contaminated, fill in the VAT form «Contamination and Radiation Report» and send it with the product. The form is available at VAT. The maximum values indicated in the form must not be exceeded.

5.1 Maintenance procedures



Keep fingers out of the valve during maintenance work.



Use cleanroom gloves during maintenance work.

One **preventive maintenance** procedure is defined for this product. This is:

Replacement of actuator feedthrough seals and valve cleaning.



Required frequency of cleaning and replacement of seals is depending on process conditions.

A critical factor influencing the maintenance period is the lifetime of the vacuum grease, being limited under increased temperature. In this case grease will separate to PTFE and oil. The oil may flow and contaminate the valve parts.

VAT can give the following **recommendations for preventive maintenance**:

	unheated *)	heated $\leq 80^{\circ}\text{C}$ *)	heated $> 80^{\circ}\text{C}$ *)
actuator feedthrough seals	2'000'000 cycles	6 months but max. 2'000'000 cycles	3 months but max. 2'000'000 cycles



*) These figures are reference values for clean conditions under various temperatures. These values do not include any impact of the process. Therefore preventive maintenance schedule has finally to be checked for the actual process conditions.





Furthermore the following maintenance procedures are described:

Replacement of **plate**

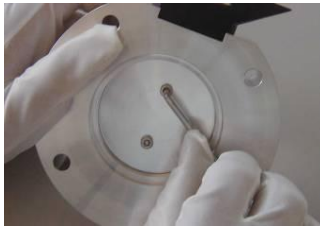

Replacement of **control and actuating unit** or **valve unit**

Replacement of **valve body** or **mechanical unit**

Description		Required tool
Remove valve from system	<p>1. Note: Make sure that the valve is in closed position</p> <p>2. Vent vacuum system, disconnect electrical connections and remove valve from vacuum system. If you only replace control and actuating unit, the valve can remain in the system.</p> <p>Note: Take care not to damage the sealing surface!</p> <p>Attention! Do not move the plate by hands when control and actuating unit is installed.</p>	Depending on flange screws
Remove control and actuating unit from valve unit	<p>3. Unfasten clamp coupling</p> 	Allen Wrench 2mm
	<p>4. Unfasten the 2 connection bolts and separate both parts.</p> <p>Note: Valve size DN 160 (6") and bigger require a shortened wrench. For ordering number refer to «Spare parts and accessories».</p> <p>12 mm </p> 	Allen Wrench 3mm
Remove plate	<p>5. Unfasten screws and remove plate from shaft.</p> 	Allen Wrench 3mm

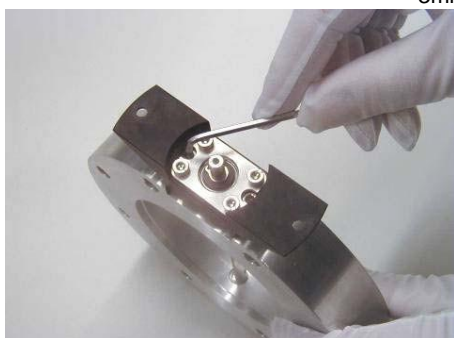
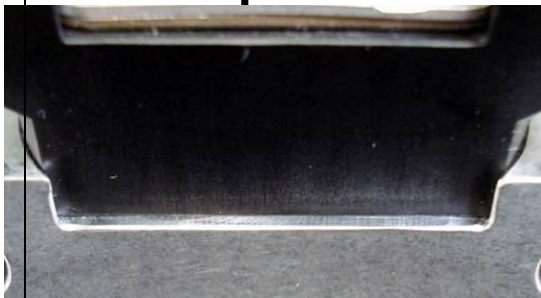
Description		Required tool
Remove and clean mechanical unit	<p>6. Unfasten alternately the 2 mounting screws little by little.</p> <p>Note: If only one screw is fasten / unfasten, the mechanical unit will be damaged. Max. difference should be less than 1 turn or 0.5 turn of the screws.</p>	  Allen Wrench 3mm
	<p>7. Remove mechanical unit and clean shaft.</p>	
Seal removal and valve cleaning	<p>8. Remove o-rings.</p> <p>9. Clean shaft feedthrough and valve body.</p>	
Lubricate and install seals	<p>10. Lubricate seal contact surface of valve body with a slight film of vacuum grease (0.025 ml).</p> <p>11. Lubricate each o-ring with a slight film of vacuum grease (0.0125 ml).</p>	

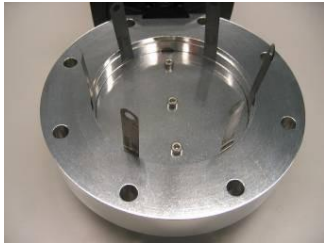
Description		Required tool
	<p>12. Lubricate seal contact surface of shaft with a slight film of vacuum grease (0.0125 ml).</p> <p>13. Slide both o-rings onto shaft till the end.</p> <p>14. Deposit 0.0375 ml vacuum grease between the o-rings</p> <p>15. Clean shaft from vacuum grease.</p>	
Mount mechanical unit to valve body	<p>16. Assemble mechanical unit in reverse order as disassembled (steps 6 to 5).</p> <p>17. Align pedestal parallel to valve body and tighten the 2 mounting screws with 2 Nm.</p>	<p>Allen Wrench 3mm</p>  

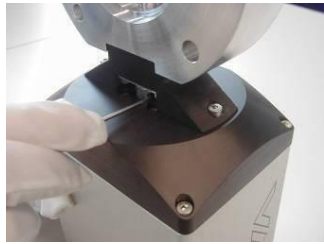
Description		Required tool	
Assemble and adjust plate	18. Center plate.	 <p>Allen Wrench 3mm</p> <p>Adequate feeler gauge</p>	
	Size		Feeler gauge mm
	25		0.04
	40		0.04
	50		0.04
	63		0.04
	80		0.06
	100		0.06
	160		0.06
	200		0.08
250	0.1		
	19. Tighten plate screws with 2 Nm.		
Mount control and actuating unit to valve unit	20. Assemble control and actuating unit to valve unit. Tighten mounting screws adequately.	 <p>Allen Wrench 3mm</p>	
	21. Tighten clamp coupling with 1.1 Nm.	 <p>Allen Wrench 2mm</p>	
Install valve into system	22. Reinstall valve into vacuum system according to chapter «Installation».		

5.2 Option board

The option board may or may not be equipped in your valve depending on the order. Refer to page 1 of this manual to check valve version. This board includes the optional modules for the valve which are:

- $\pm 15\text{VDC}$ sensor power supply (SPS)
- Power failure option (PFO)

It is available in 3 versions. These are:

- SPS module only
- PFO module only
- SPS and PFO module

The modules may be retrofitted or replaced easily. The battery lifetime of the PFO module depends on the ambient temperature (see below). To assure PFO function the option board must be replaced after battery life has expired. For ordering number of the modules refer to «Spare parts and accessories».

5.2.1 Durability of power fail battery

The curves in the graph show the estimated life of UltraCap PFO in the worst condition (max. sensor load = 1 A, valve heating temperature = 150 degree C).

If the SPS is not fully loaded (< 1 A) or heating temperature of valve body is lower than 150 degree C, the corresponding life time curve will be somewhere in between the upper and the lower curve.

Therefore please determine the equivalent maintenance period for replacing the UltraCap battery (Option board).

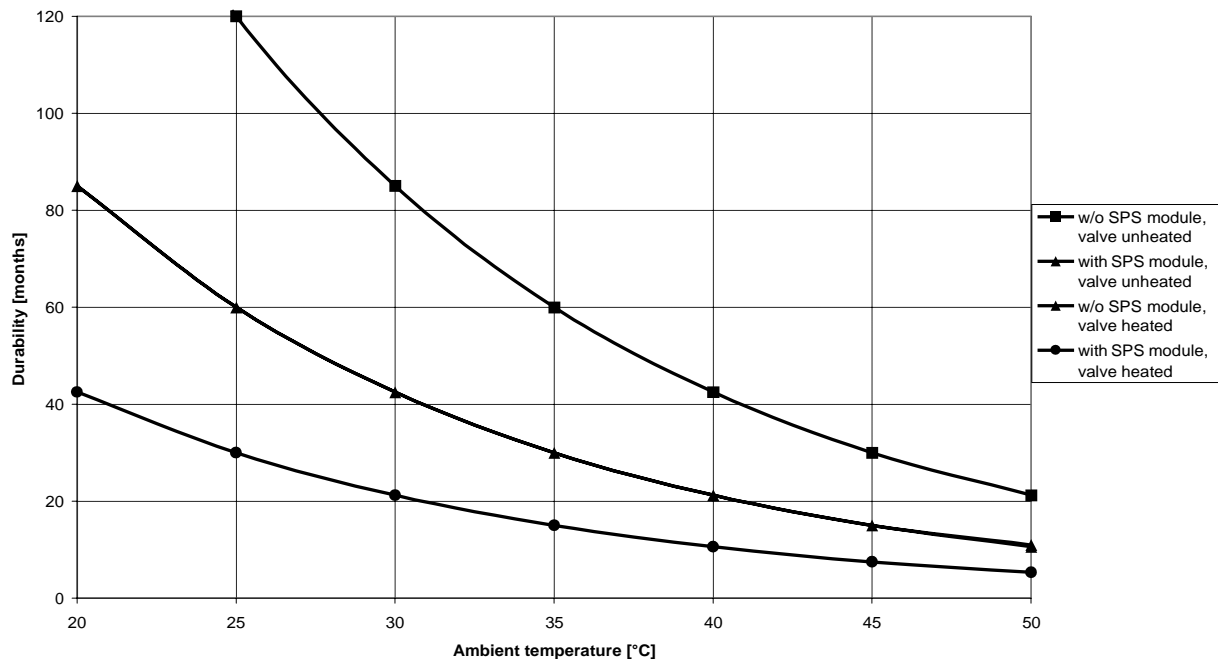

Note: This graph shows estimated life of UltraCap PFO for reference and not as guaranteed value.

5.2.2 Retrofit / replacement procedure





ESD Precaution!

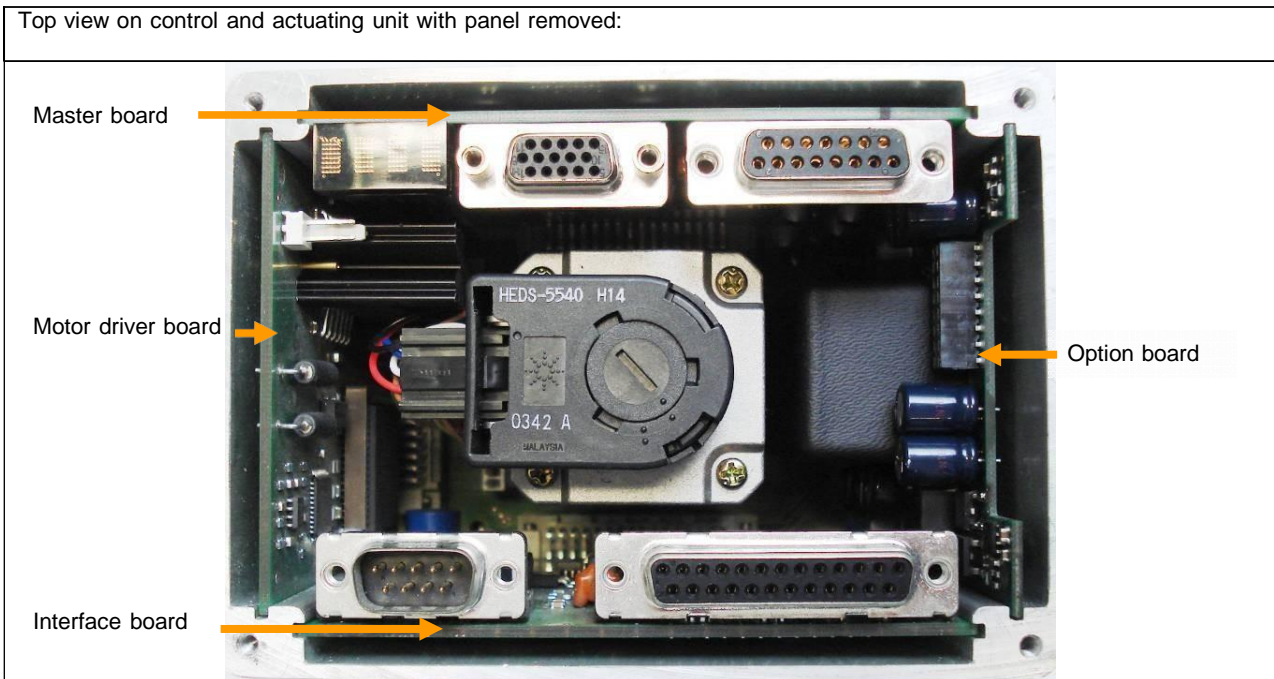

All work on the control and actuating unit has to be done under ESD protected environment to prevent electronic components from damage!

Top view on control and actuating unit with panel removed:

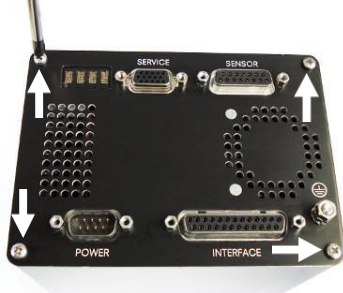
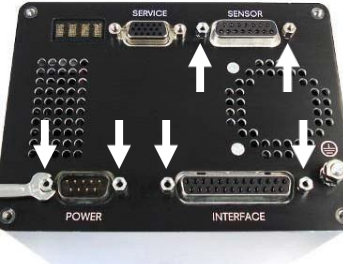

Note: All boards have a fixed position into control and actuating unit. It is not possible to fit a board in other position as shown in picture above. Do not try out other positions, that may be destroy the socket of boards!

Description		Required tool
1. Remove the panel screws.		Pozidriv screw driver size 1
2. Remove female screw locks from POWER, SENSOR and INTERFACE connectors.		Open end wrench 4.5 mm
3. Lift the panel carefully.		
4. Disconnect fan cable from board.		

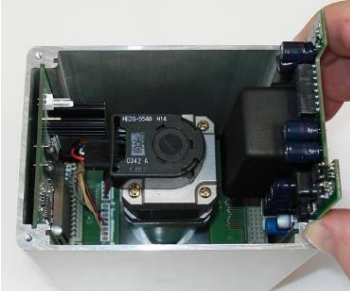
Description		Required tool
5. Remove or replace master board.		
6. Remove or replace interface board.		
7. Remove or replace option board.		
8. Insert master board and interface board in reverse order as disassembled at correct positions (see steps 6...5).		
9. Insert option board at correct position (see step 7).		
10. Reconnect fan cable (see step 4).		
11. Place the panel and tighten screws with 1.1 Nm (see steps 3...2).		Pozidriv screw driver size 1
12. Tighten female screw locks from POWER, SENSOR and INTERFACE connectors with 12.1 Nm (see step 1).		Open end wrench 4.5 mm

6 Drawing

